

4

3

2

1

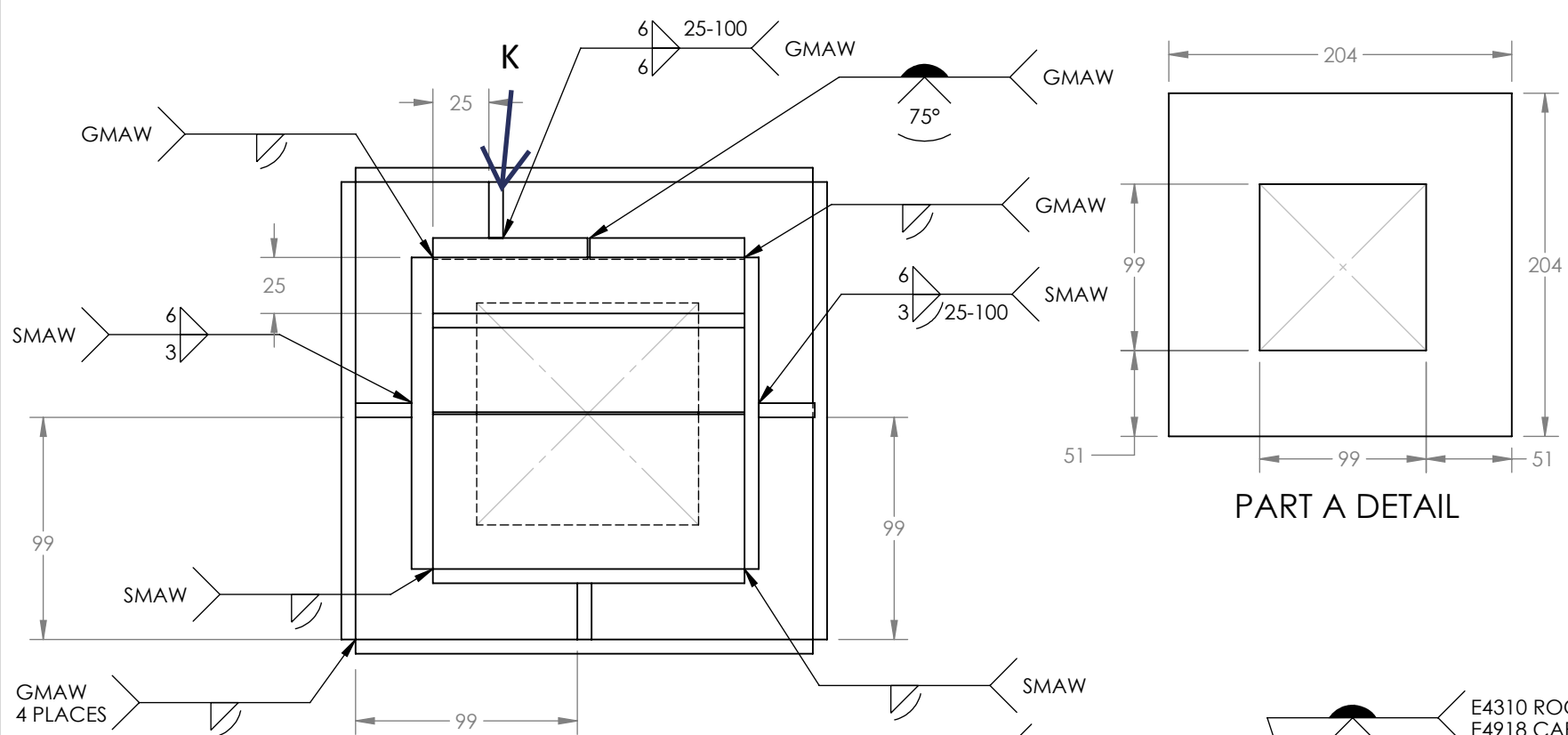

PART A DETAIL

| ITEM | T | W | L | QTY | KG | NOTE |
|------|------|-----|-----|-----|----|-------|
| A | 6.35 | 204 | 204 | 1 | 3 | SHAPE |
| B | 9.53 | 139 | 154 | 1 | 2 | |
| C | 6.35 | 139 | 154 | 2 | 3 | |
| D | 6.35 | 25 | 104 | 2 | 1 | |
| E | 6.35 | 25 | 154 | 1 | 1 | |
| F | 9.53 | 69 | 139 | 2 | 2 | BEVEL |
| G | 9.53 | 69 | 154 | 2 | 2 | BEVEL |
| H | 6.35 | 25 | 204 | 4 | 2 | |
| J | 6.35 | 25 | 139 | 1 | 1 | |
| K | 6.35 | 25 | 139 | 1 | 1 | |

NOTES:

- ALL DIMENSIONS MILLIMETRES
- ALL MATERIALS MILD STEEL
- TACK ALL ITEMS TOGETHER BEFORE ANY WELDING COMMENCES
- FOR SMAW USE E4918 ELECTRODES, EXCEPT AS NOTED
- ALL VERTICAL WELDING PROGRESSION VERTICAL UP
- PROJECT MUST REMAIN FLAT ON ITS BASEPLATE DURING WELDING
- ONCE FITTING IS COMPLETED, PROJECT MUST BE STAMPED PRIOR TO WELDING
- ROOT GAP AND EDGE PREPARATION YOUR CHOICE
- TIME LIMIT: 6 HRS

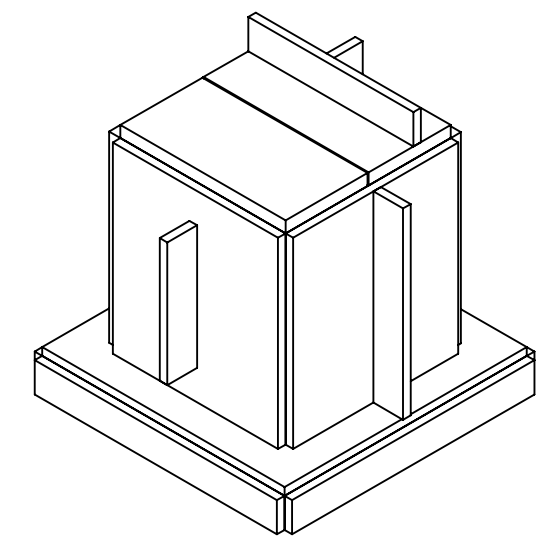
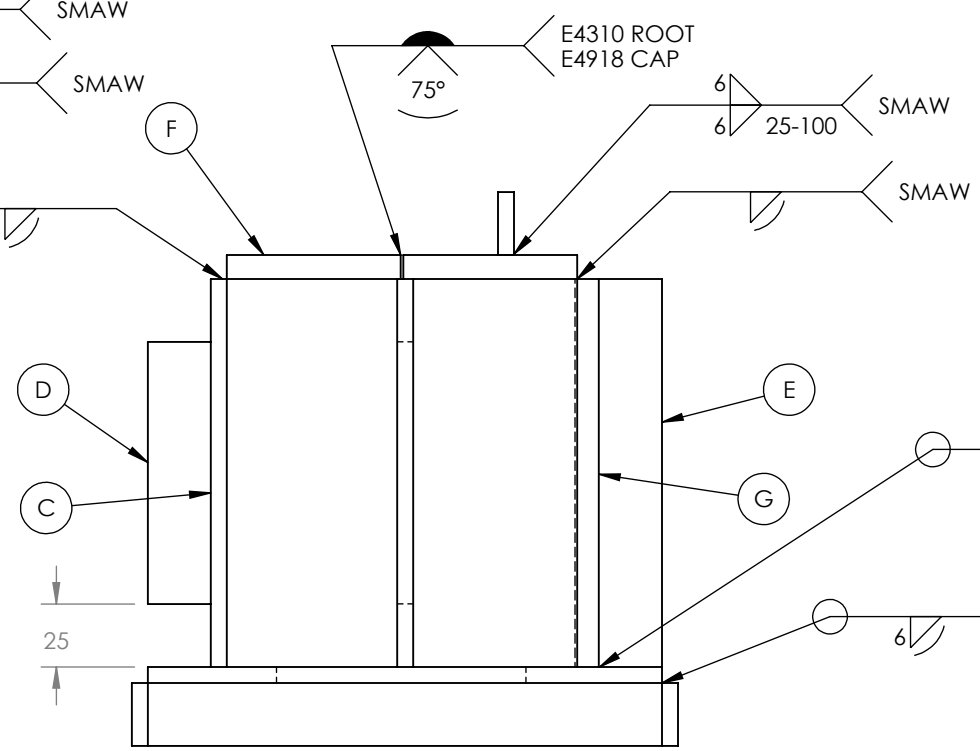
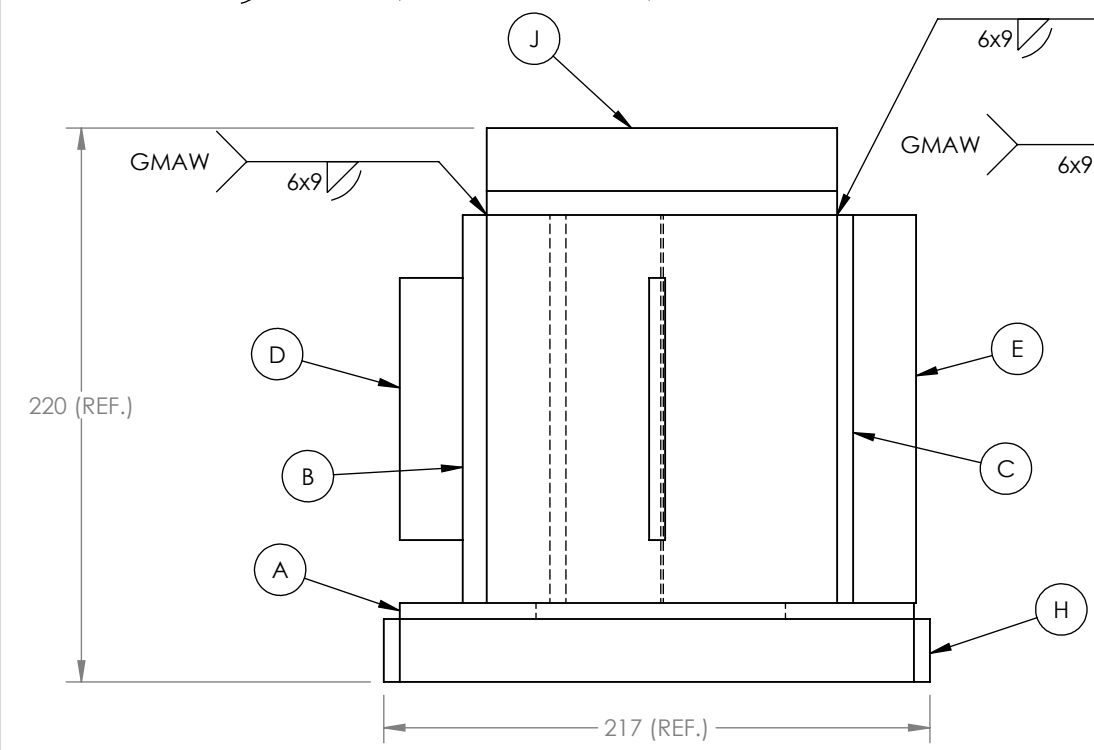

ISOMETRIC VIEW (NTS)

WELD DETAIL:

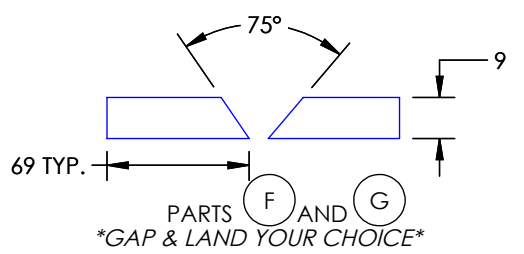

TITLE: 2021 SCNC - JK BOX
GENERAL ARRANGEMENT / PLAN D'ENSEMBLE

SHEET #: 1 OF 1
SIZE: B

DWG. NO.: 2021-CS-1A
REV.: 1
SCALE: NTS

DRAWN BY: J. HYDE
DATE: 2020-12-16

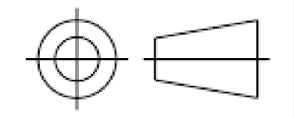

4

3

2

1