

Laser Tripwire

Electronics

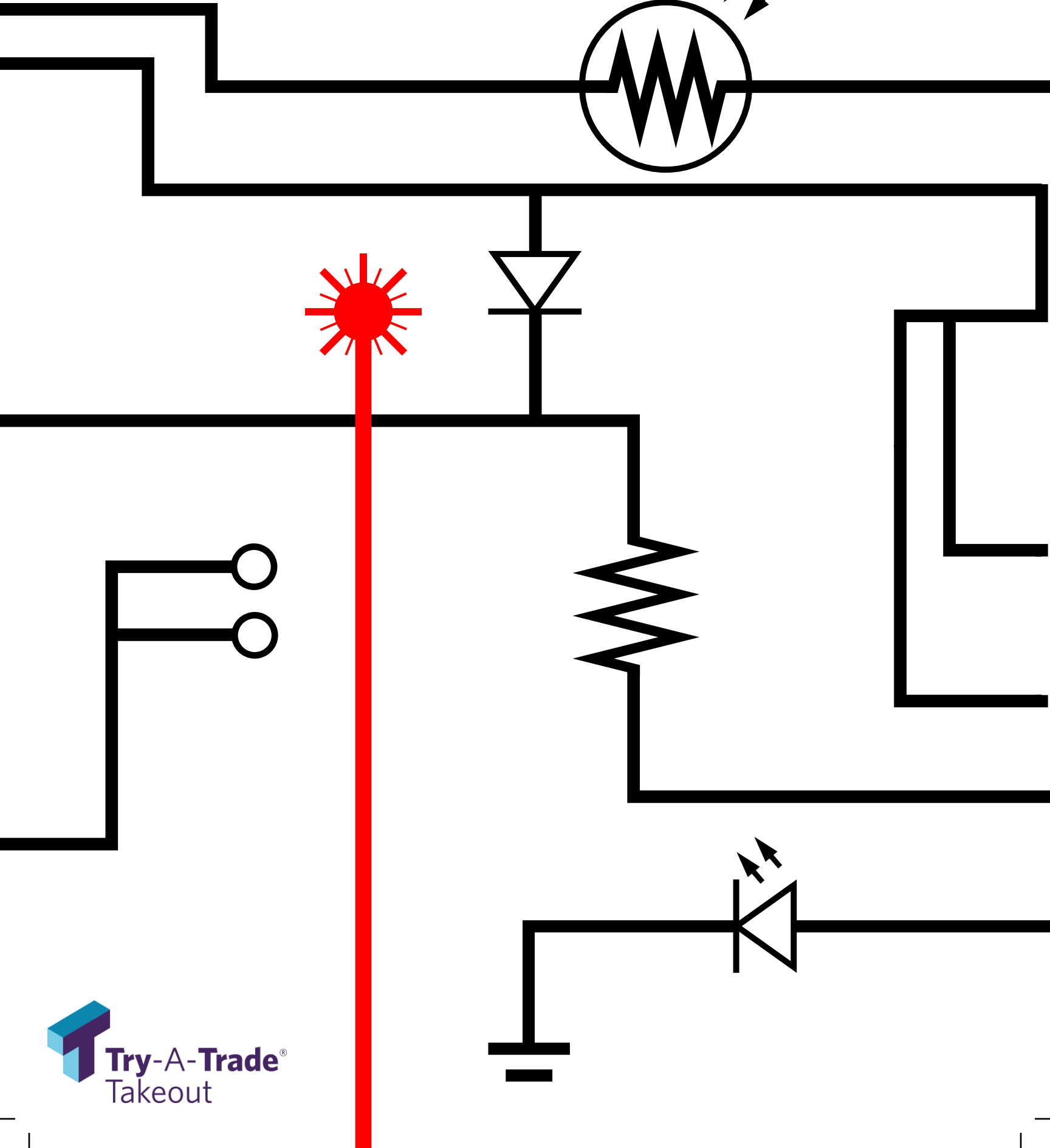

Laser Tripwire

Provided Materials

- | | |
|-------------------|-----------------------|
| 1. Wire strippers | 9. Battery packs |
| 2. Jumper wires | 10. Breadboard |
| 3. Laser diode | 11. Wire connectors |
| 4. LED | 12. Glue |
| 5. Photoresistor | 13. Double-sided tape |
| 6. Resistor | 14. Base pieces |
| 7. Transistor | 15. Drilled posts |
| 8. AA Batteries | |

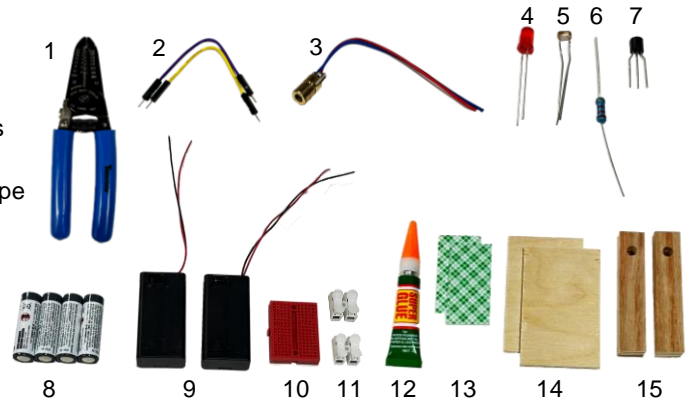



Safety First.
Do not look directly at the laser.

1. Glue the posts as shown (holes out). Tape the battery packs to the bases for sides A and B.

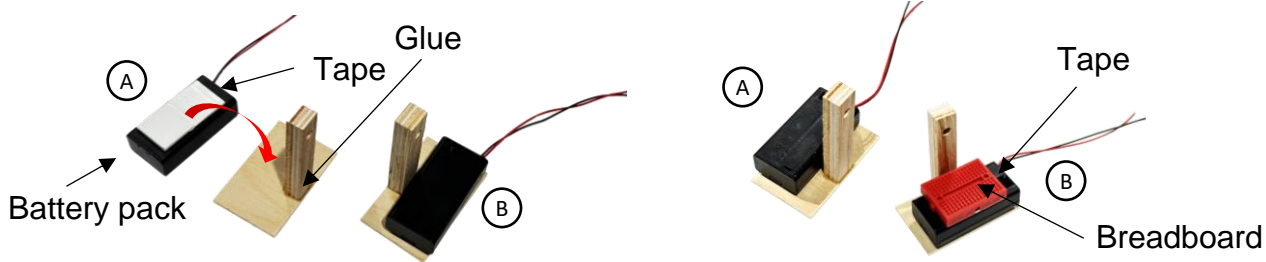

2. Follow the wiring diagrams below for sides A and B.

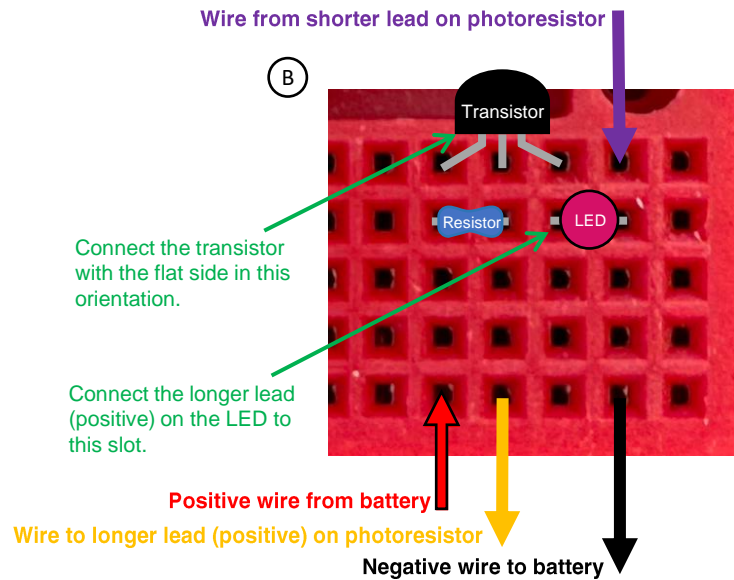
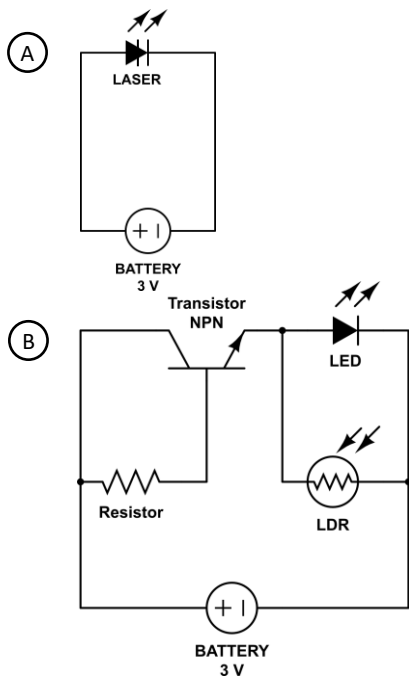

3. Tape the connectors to the posts. Insert the photoresistor and laser diode into the holes in their respective posts. If assembled and aimed correctly, the LED will light when the photoresistor is not illuminated by the laser beam.

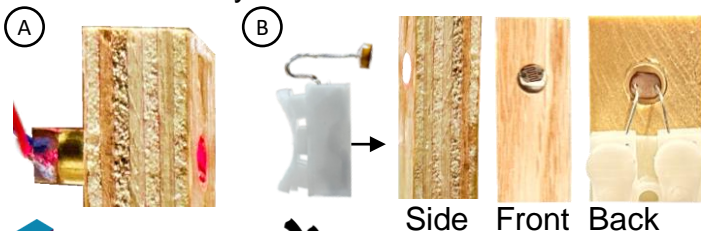

Transistors

Transistors control the flow of electricity without the use of a physically moving switch. This is achieved using semiconductors.

Semiconductors are combinations of materials that allow electricity to flow only under certain conditions. Made with either an excess or a lack of valence electrons, semiconductors are sensitive to the direction and polarity of current. Transistors use this property to control current flow by sandwiching two types of semiconductor materials together and providing a signal voltage to the material. This signal balances the valence electron counts in the semiconductor and allows current to flow, but only while the signal current is active.

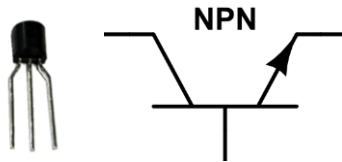

Resistors

An electric current is formed when electrons flow through a complete circuit.

A resistor restricts the number of electrons that can flow through a circuit, turning their energy to heat or light instead of electricity.

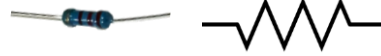

Light Emitting Diodes

Light Emitting Diodes or LEDs operate in a similar method to laser diodes. A key difference is that LEDs emit “incoherent” light, which is a mixture of light phases and spectrums as opposed to laser light’s purer phase and spectrum band. LEDs are much more efficient to operate compared to laser diodes.



Laser Diodes

LASER is an acronym that stands for Light Amplification by Stimulated Emission of Radiation.

Lasers are made of optical materials (glass, crystal, or gas) that emit a narrow beam of light, called “coherent light”, when stimulated by an electrical current or light.

A diode is a semiconductor device that allows current to flow in one direction only.

A laser diode is a semiconductor device that reacts to an electric current to emit a single wavelength of light.



Breadboards

The inside of a breadboard is filled with sets of parallel conductive “bus bars” that carry the current along their own line.

Breadboards allow for easy component connections.

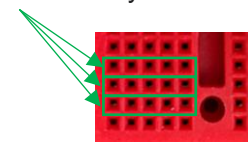

Photoresistors

Photons are the particles that make up light. They have no mass, but each carries a specific amount of energy.

A photoresistor (Light Dependent Resistor or LDR) is a type of resistor that reacts to light. When light hits a photoresistor, it absorbs photons. The energy in the photons conducts electricity through the circuit. This is called “photoconductivity”.



Laser Tripwire

Project

Students learn about transistors, resistors, and semi-conductors to construct a laser-activated sensory device.



Electronics

Schooling

- Education varies depending on sector and job.
- Start early with the Registered Apprenticeship Program (RAP) or explore options available through Career and Technology Studies (CTS).

Jobs

- Electronic and Avionics Engineers, Automotive Technicians, and many more.
- Develop, maintain, and deploy electrical components, systems, and infrastructure.
- Average salary: \$64, 714.00 - \$103,500.00/year
- Average wage: \$31.12 - \$51.35/hour

More information:



Find your trade:

Or visit:

tradesecrets.alberta.ca



Apprenticeship
and Industry
Training

Plan your career:

Or visit:

alis.alberta.ca



Send us photos of your projects,
and tag us on social media:



#skillsalberta

@skillsalberta

@skillsalberta

