

Squirrel Picnic Table A

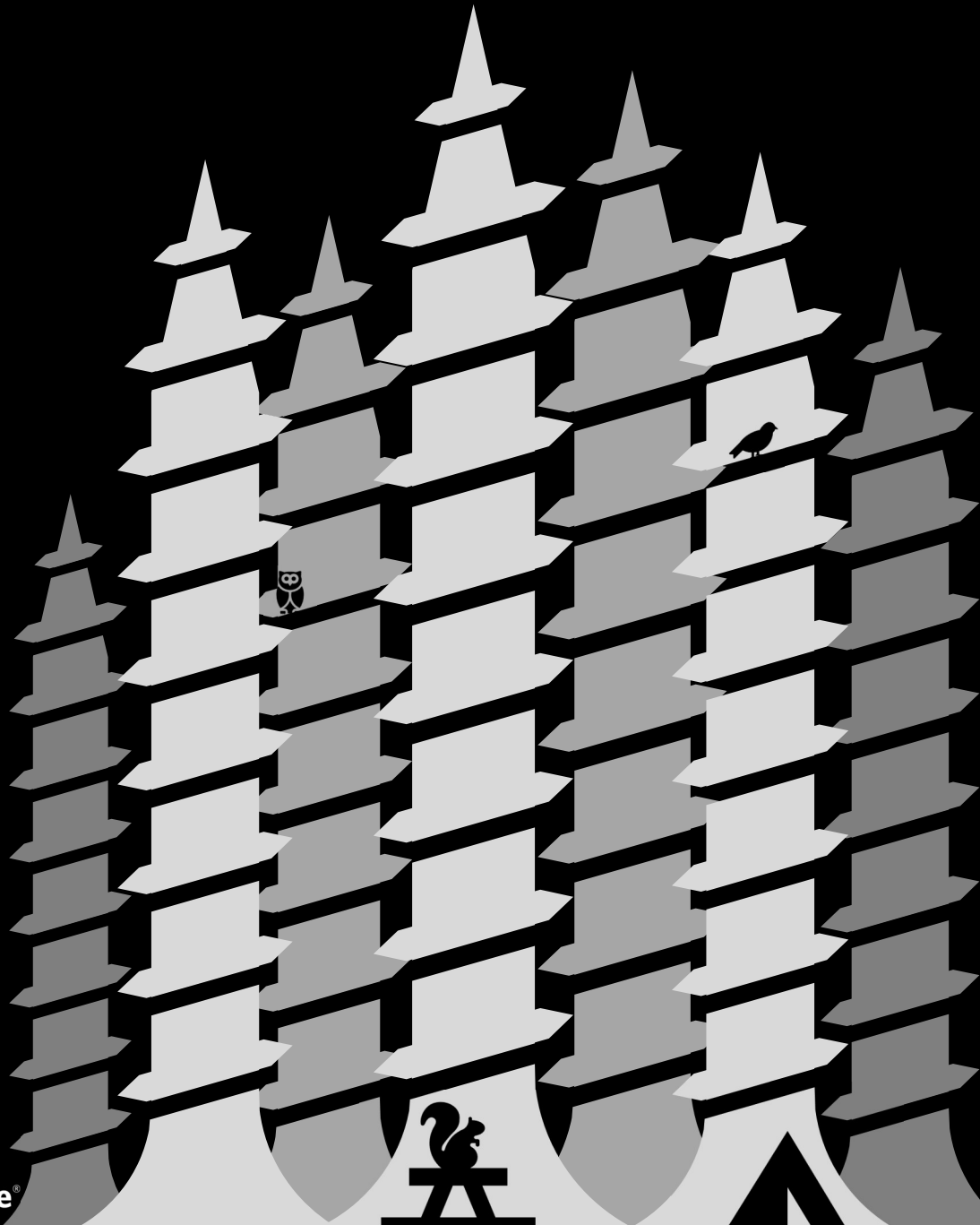

Carpentry



Squirrel Picnic Table

- Provided materials:**
- | | |
|-----------------------------|----------------------------|
| 1. Gloves | 6. Square |
| 2. Glasses | 7. 1/8" drill bit |
| 3. Screw x18 | 8. Drill |
| 4. Robertson #2 screwdriver | 9. Wood pieces (see below) |
| 5. ADD CLAMP? | |



Safety First.

Before you begin, put on your gloves and safety glasses.

Preparation

1. Refer to the diagrams on this page to measure and clearly mark all pieces.
2. Drill all holes. Drill marks are indicated by the circled dashes across lines: ⊕ **MEASURE TWICE, DRILL ONCE.**

A) Tabletop x1, 3 pieces together

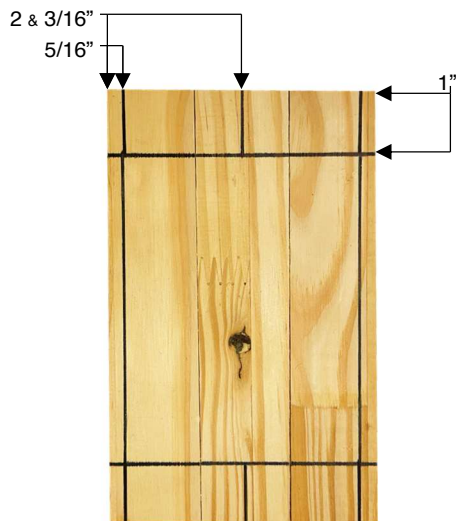

B) Seat x2



C) Seat support x2

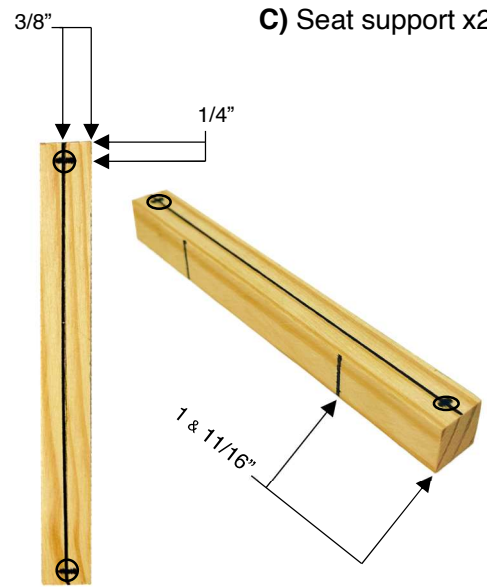

D) Leg x2 – one end of table

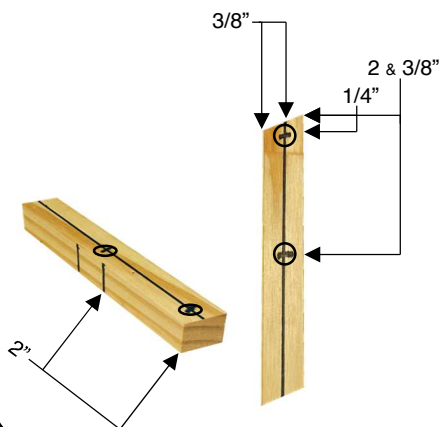

E) Leg x2 – other end of table

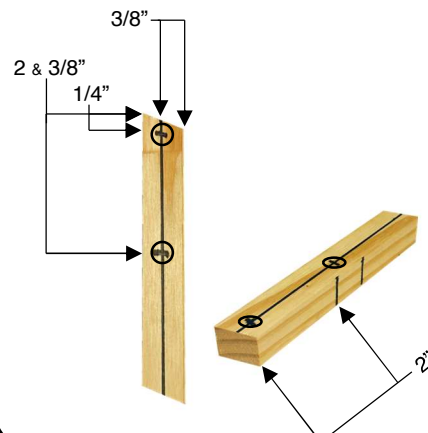

F) Tabletop brace x2

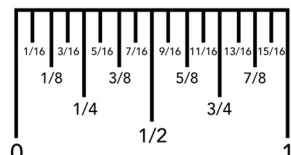
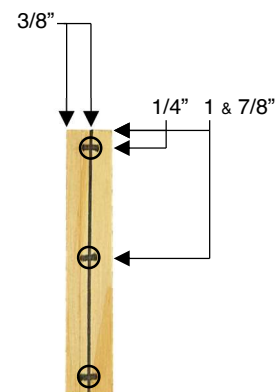

Construction

1. Attach the tabletop braces (F) to the tabletop (A).



Drilling holes

When drilling, use a clamp to secure the part to a stable surface, and overhang the drill mark off the edge of the surface.

Do not hold the wood in your hand while drilling.



2. Attach the legs (D and E) to the tabletop brace (F) on each side, using the centre line as a reference.



3. Attach one seat support (C) to the insides of the legs on each side.



4. Attach one seat (B) to the seat support (C) on each side.



The Robertson Screwdriver

Invented in 1908 by a Canadian travelling tool salesman, Peter Lymburner Robertson, after he had cut his hand demonstrating a slotted screwdriver that slipped out of the screw.

The tapered square bit keeps the bit in the screw, allowing better control.



Follow this QR code to view the instructions in video form, or visit: www.youtube.com/@skillsalberta



Find PDF versions of these instructions at: skillsalberta.com/resources/try-a-trade-take-out



Try-A-Trade® Takeout Program

Activity: Squirrel Picnic Table

V4

Skill Area: Carpentry

CTS Cluster: TMT

Squirrel Picnic Table ~~XX~~

Carpentry

Project

In this pint-sized glimpse into the day-to-day work of a carpenter, students read blueprints and use carpentry tools to assemble a miniature picnic table for urban wildlife.



Schooling

- Four-year apprenticeship
- Red Seal Journeyperson.
- Start early with the Registered Apprenticeship Program (RAP) or explore options available through Career and Technology Studies (CTS).

Jobs

- Construct, renovate, and repair structures made of wood, steel, concrete, and other materials.
- Work around the province, indoors and out.
- Average salary: \$72,252.00/year
- Average wage: \$33.27/hour

More information:



Find your trade:

Or visit:

tradesecrets.alberta.ca



Apprenticeship
and Industry
Training

Plan your career:

Or visit:

alis.alberta.ca



Send us photos of your projects,
and tag us on social media:



#skillsalberta



@skillsalberta



@skillsalberta



Try-A-Trade
Takeout



Skills Canada
Alberta

