

# Shoot the Moon

Carpentry



# Shoot the Moon Game

- Provided Materials**
- 2 steel rods (A)
  - 1 ball bearing (B)
  - 1 Forstner bit (C)
  - 4 long screws (D)
  - 4 short screws (E)
  - 8 spacers (nuts) (F)
  - 4 felt pads (G)
  - Wood pieces (H-J)
  - Large wood base plate
  - Paper marking template (17" x 3.5")
  - Robertson #2 screwdriver
  - 1/8" drill bit
  - Safety glasses
  - Work gloves

- Required Materials**
- Pencil
  - Variable-speed drill

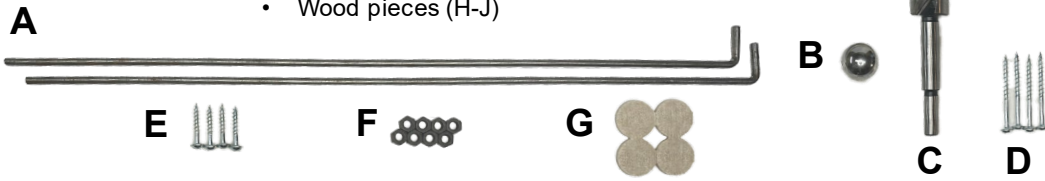

## H) Front board

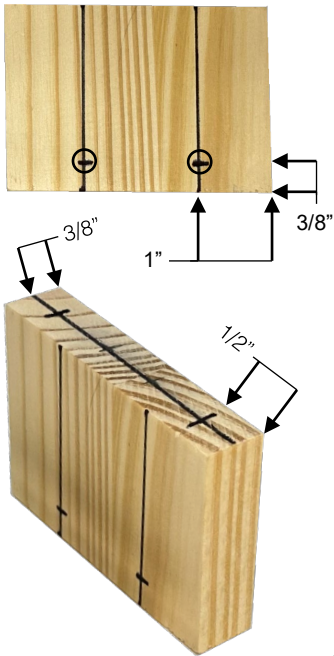

## I) Rear board

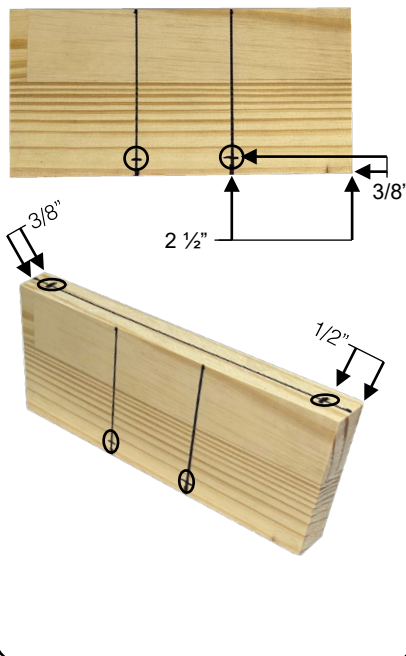

## J) Board caps



## Forstner Bit

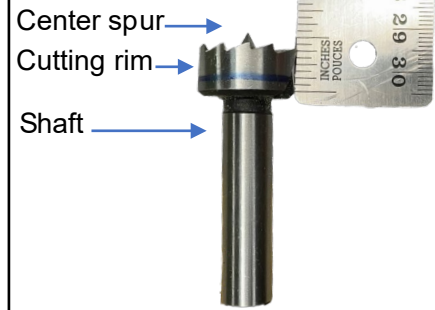

To maintain a consistent drill depth, use a marker to draw a line 1/8<sup>th</sup> of an inch down from the top of the bit. Stop drilling when this line is even with the top of the material.

Patented in 1886 by American inventor Benjamin Forstner.

Forstner bits cut holes that are smooth on the sides and flat on the bottom.

They have a spur at the center to hold the cutting rim place as you start to drill.



## Safety First.

Before you begin, put on safety glasses and work gloves.

## Instructions

1. Prepare to drill holes in the base plate.
  - Lay the paper marking template on the base plate.
  - To mark drill holes, push the point of your pencil through the center of the cross.
2. Drill holes in the base plate.
  - Secure the Forstner bit in your variable-speed hand-held drill.
  - Place the drill bit's pivot point on one of the marks you made with your pencil.
  - Hold the drill upright.
  - On low speed, drill until the line you drew on the bit is level with the top of the wood. (Fig. 1)



Fig. 1

3. Attach the front board and rear board to the base plate.

- With the holes on the front board (H) to the bottom, draw a mark  $1\frac{3}{4}$ " from each edge, as shown in Fig.2. Use these lines to center the front board with the base plate. When aligned, predrill the screw position in the baseplate through the end boards to prevent splitting the wood when inserting the screws.
- Using 2 the 4 shorter screws (E), secure the front board (H) to the base plate, as shown in Fig.3.
- Using the other 2 shorter screws (E), secure the rear board (I) to the base plate, as shown in Fig.4 .



Fig. 3

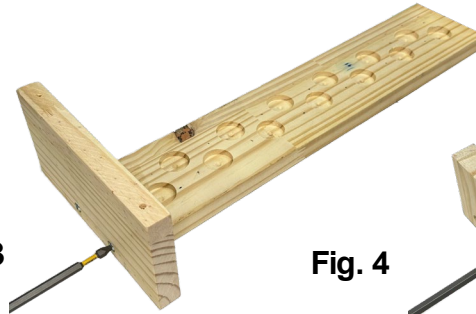

Fig. 4



4. Attach the steel rods and rear board cap.

- Insert the steel rods (A) into the holes on the top of the rear board (I).
- Attach the rear board cap (J) as follows:
  - Position 2 spacers (F) over the hole on each side of the rear board (I).
  - Place the rear board cap (J) on top of the spacers.
  - Using 2 of the 4 longer screws (D), secure the cap as shown below.



The goal of the game is to coax the ball up the rods and into the pocket closest to the backboard. This game was popularized in the 1940s, with names of planets applied to the successive holes, hinting at the approaching interest in space travel and exploration.

5. Attach the front board cap.

- Attach the front board cap (J) as follows:
  - Position 2 spacers (F) over the hole on each side of the front board (H).
  - Place the front board cap (J) on top of the spacers.
  - Using 2 of the 4 longer screws (D), secure the cap as shown below.



6. Adhere felt pads (G) to the bottom of the base plate.

7. Put the ball bearing (B) on the steel rods.



Follow this QR code to view the instructions in video form, or visit: [www.youtube.com/@skillsalberta](http://www.youtube.com/@skillsalberta)

Try-A-Trade Takeout Program

Shoot the Moon Game | V1

Material: Wood

Trade: Carpentry