

**NOTE:**  
DRAWINGS FOR TRAINING PURPOSES ONLY  
COMPETITION PROJECT MAY HAVE UP TO 30% CHANGE

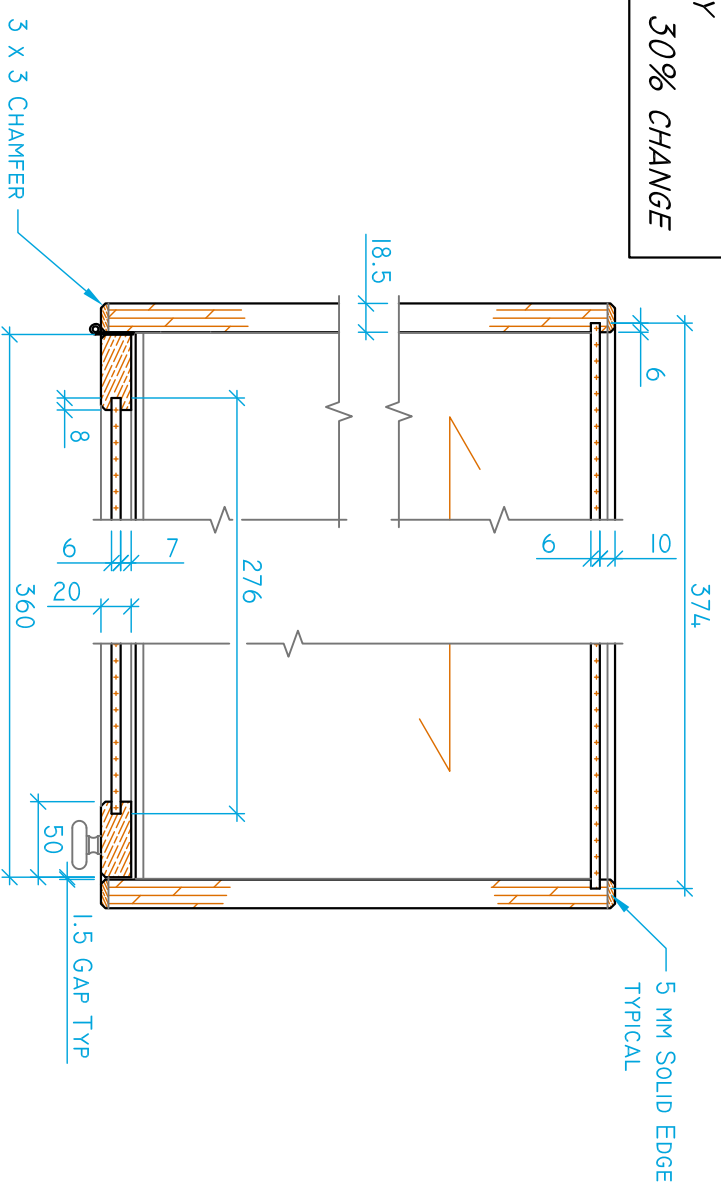

**SECTION A:A** SCALE 1:5

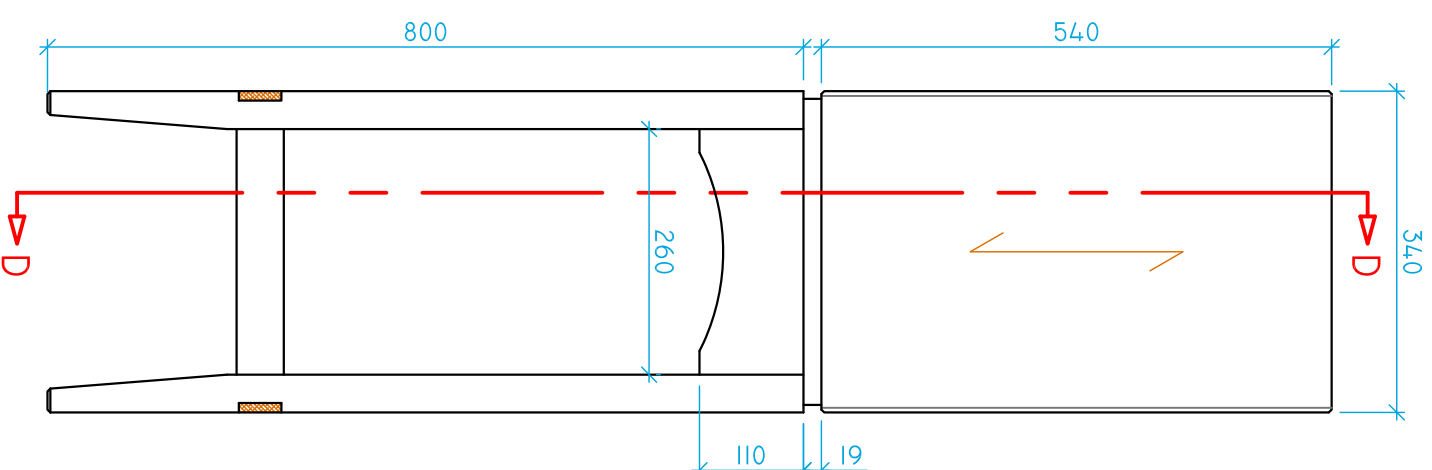
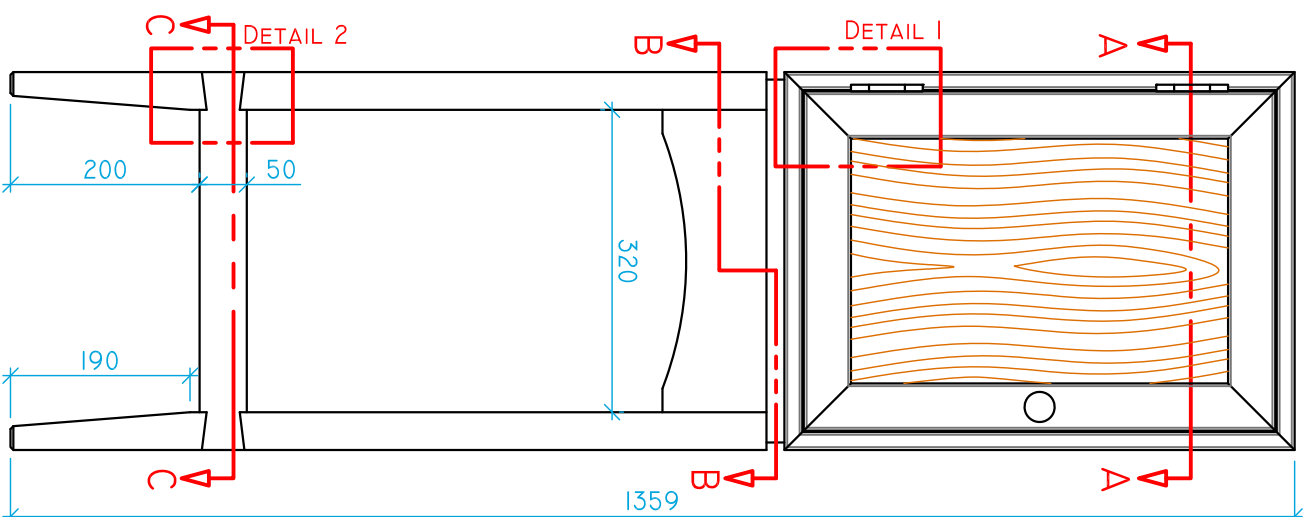
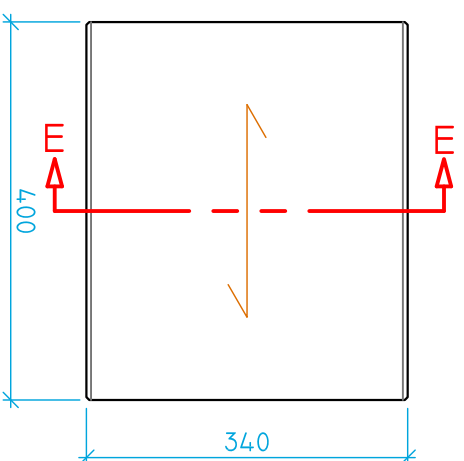
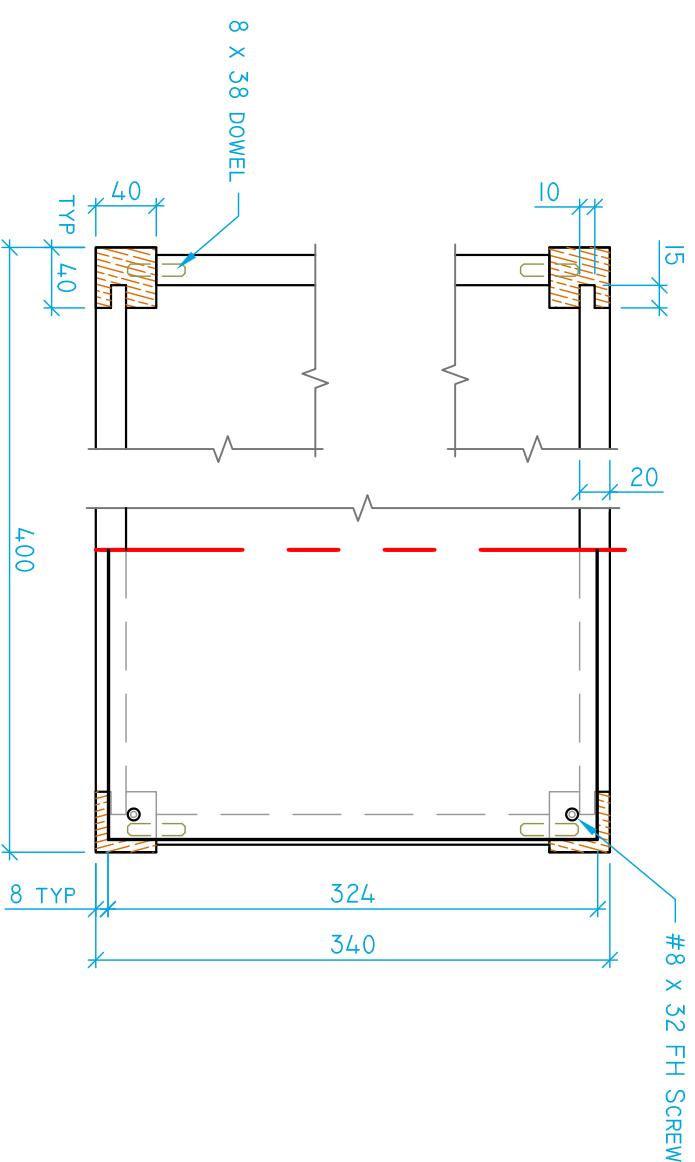

**SECTION B:B** SCALE 1:5

**ORTHO VIEWS**

**SCALE 1:8**

**NOTES:**  
UPPER CASE  
- MITRED PLYWOOD WITH 5 MM SOLID CHAMFERED EDGE  
MID PANEL  
- SUPPLIED TO SIZE WITH EDGING  
LOWER STAND  
- SOLID LEGS AND RAILS WITH MORTISE AND TENON, DOWEL AND LAP DOVETAIL JOINERY  
- TEMPLATES FOR CURVED RAIL LAYOUT WILL BE PROVIDED  
DOOR  
- MITRED FRAME WITH 6 MM PLY PANEL

**PROJECT:**  
MITRED CASE WITH STAND

**LEVEL:**  
HIGH SCHOOL

**DRAWING DESCRIPTION**  
ORTHO VIEWS SECTIONS A:A & B:B

**DATE:**  
DEC. 10, 2022

**SCALE:**  
AS NOTED

**DRAWN BY:**  
HB

**SHEET:**  
1 OF 4



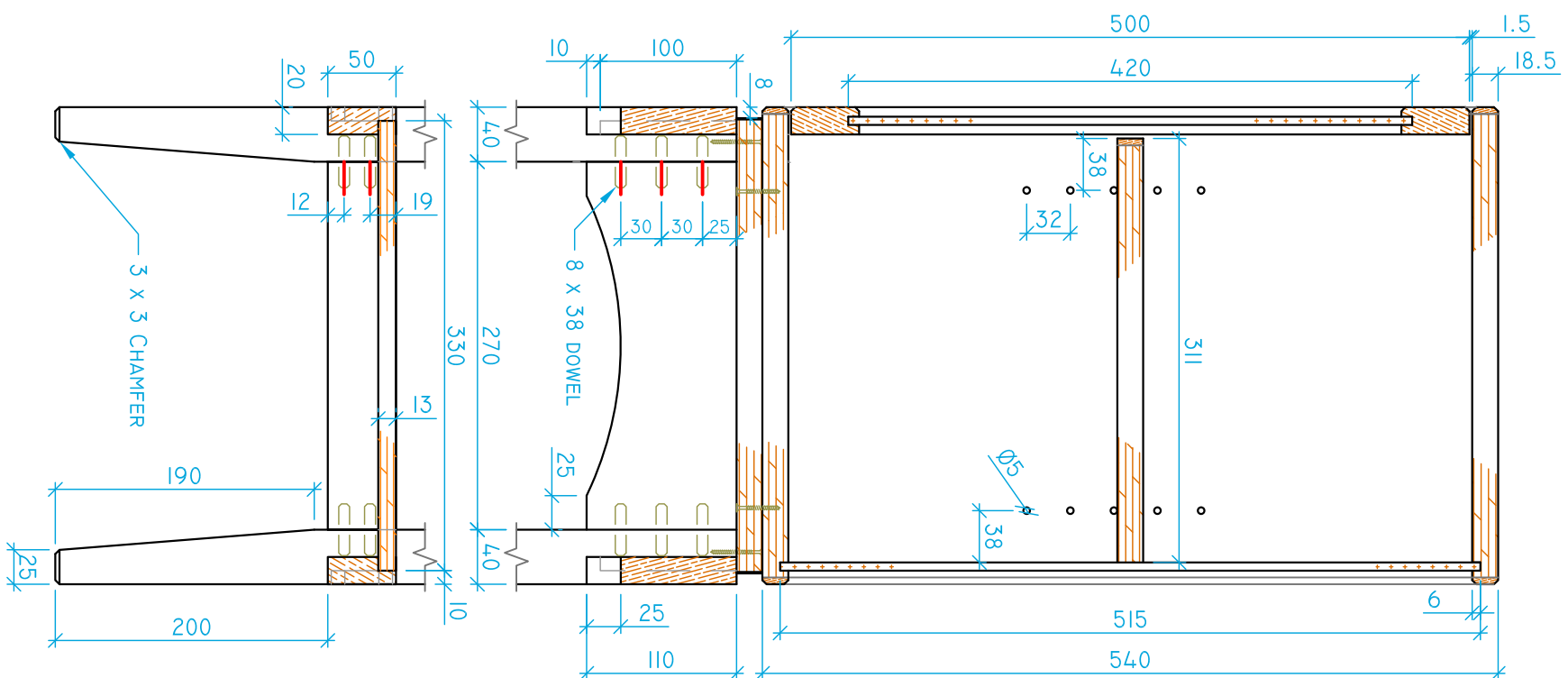

SECTION E:E SCALE 1:5

**NOTE:**  
 DRAWINGS FOR TRAINING PURPOSES ONLY  
 COMPETITION PROJECT MAY HAVE UP TO 30% CHANGE

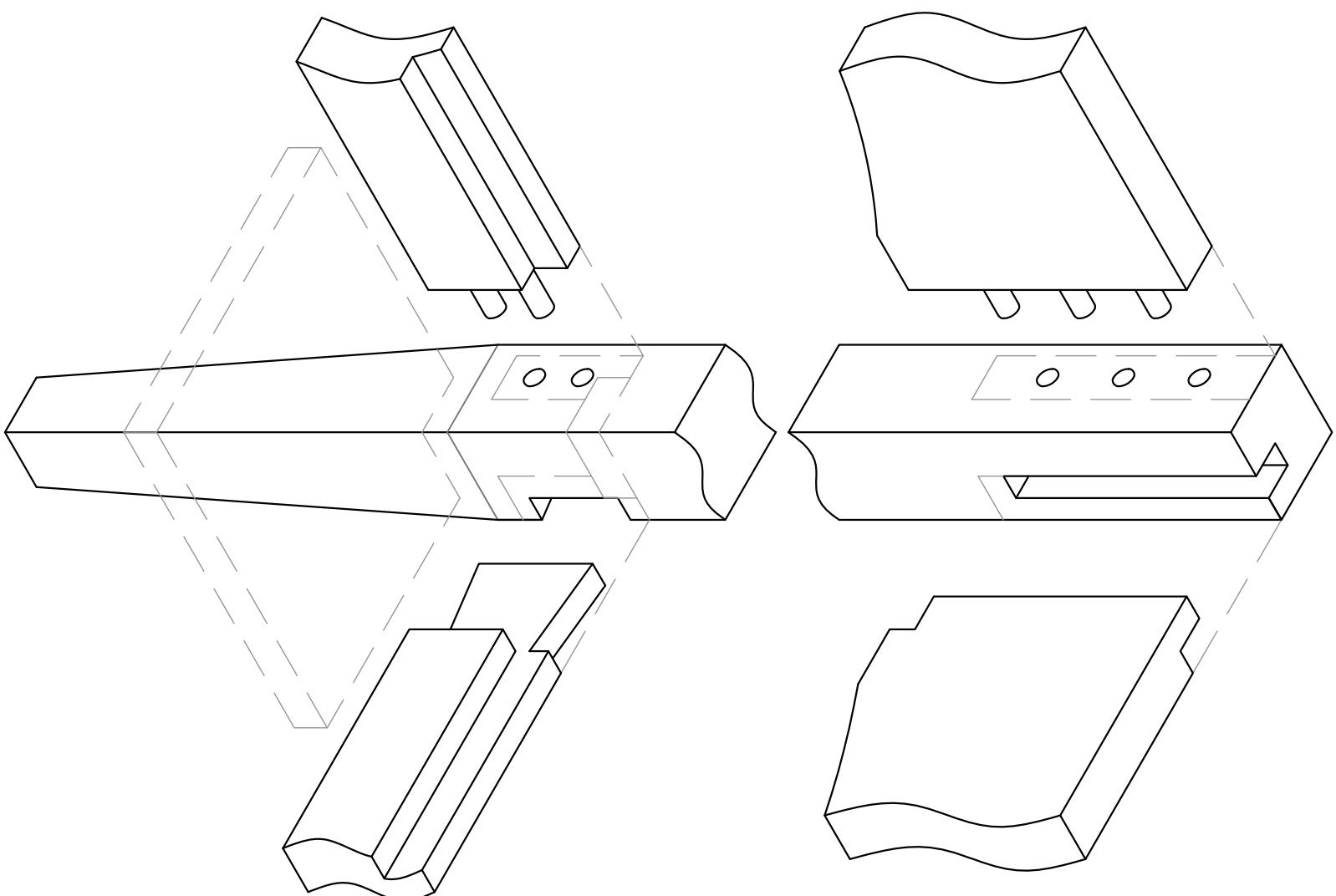

LOWER FRAME  
 EXPLODED ISOMETRIC - SCALE 1:2.5

NOTE:  
DRAWINGS FOR TRAINING PURPOSES ONLY  
COMPETITION PROJECT MAY HAVE UP TO 30% CHANGE

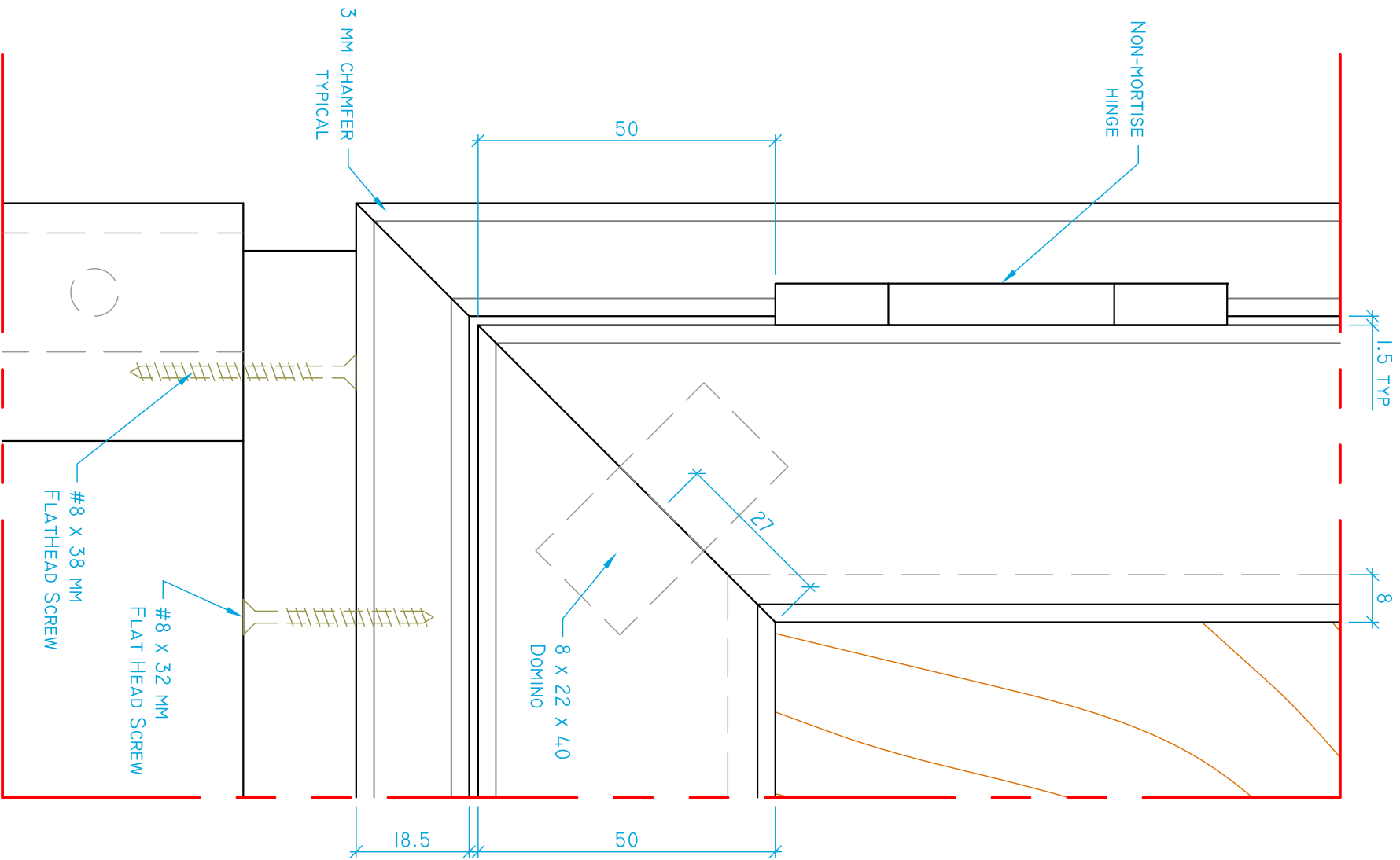

DETAIL 1 SCALE 1:1

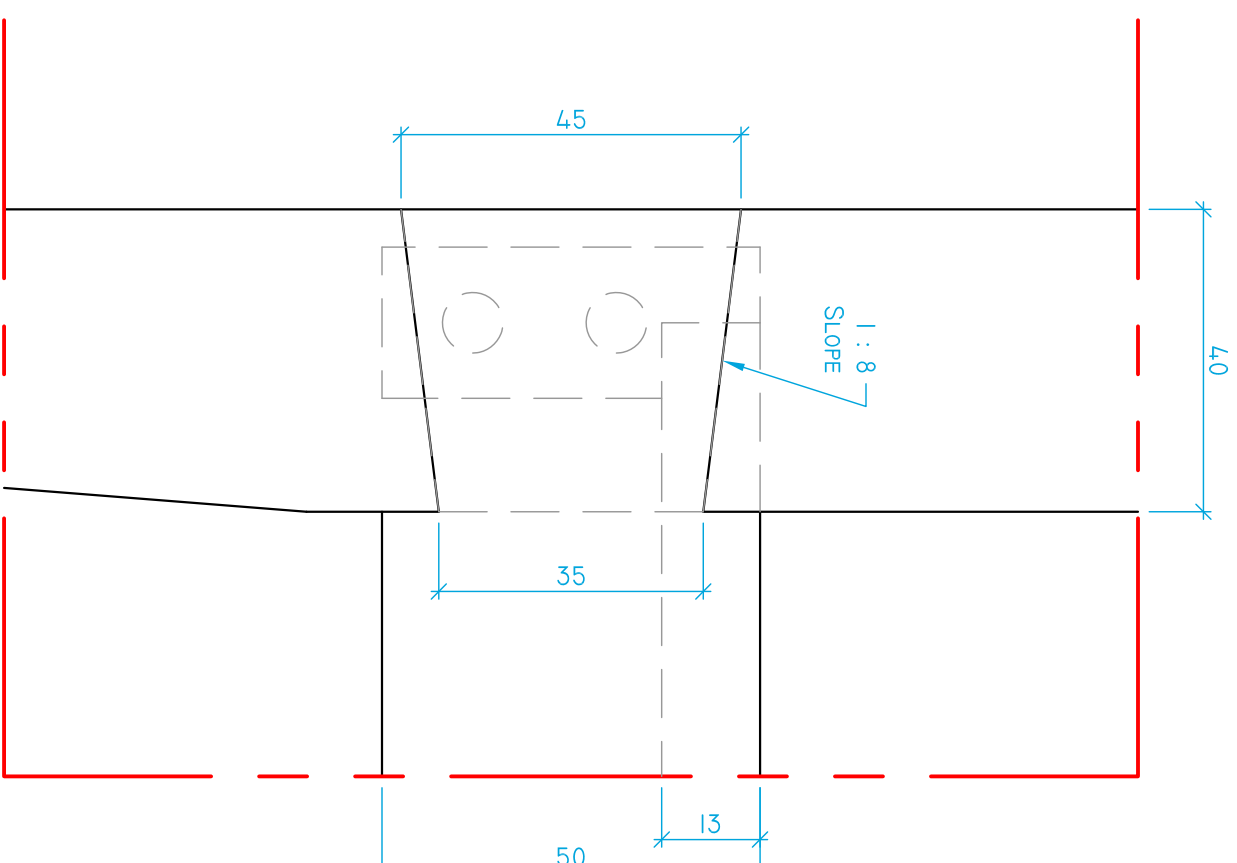

DETAIL 2 - SCALE 1:1

NOTES:  
- NON-MORTISE HINGE  
- LEE VALLEY #00H5124  
- FLOATING TENON/DOMINO JOINERY ON MITRED DOOR CORNER  
- LAP DOVETAIL JOINERY ON LOWER FRAME - HAND TOOLS ONLY - WILL BE MARKED BEFORE AND AFTER ASSEMBLY

PROJECT:  
MITRED CASE WITH STAND

LEVEL:  
HIGH SCHOOL

DRAWING DESCRIPTION  
DETAIL 1  
DETAIL 2

DATE:  
DEC. 10, 2022

SCALE:  
AS NOTED

DRAWN BY:  
HB

SHEET:  
4 OF 4