

General Notes

- 1. INDICATES MARKING POINT

| No. | Revision/Issue | Date |
|-----|----------------|------|
| | | |
| | | |
| | | |
| | | |



Project Name
SIGN POST

| | |
|-----------------------------|------------------------|
| Drawing ISOMETRIC | Sheet 1 of 4 |
| Date MARCH 2023 | |
| Scale 1:5 | |

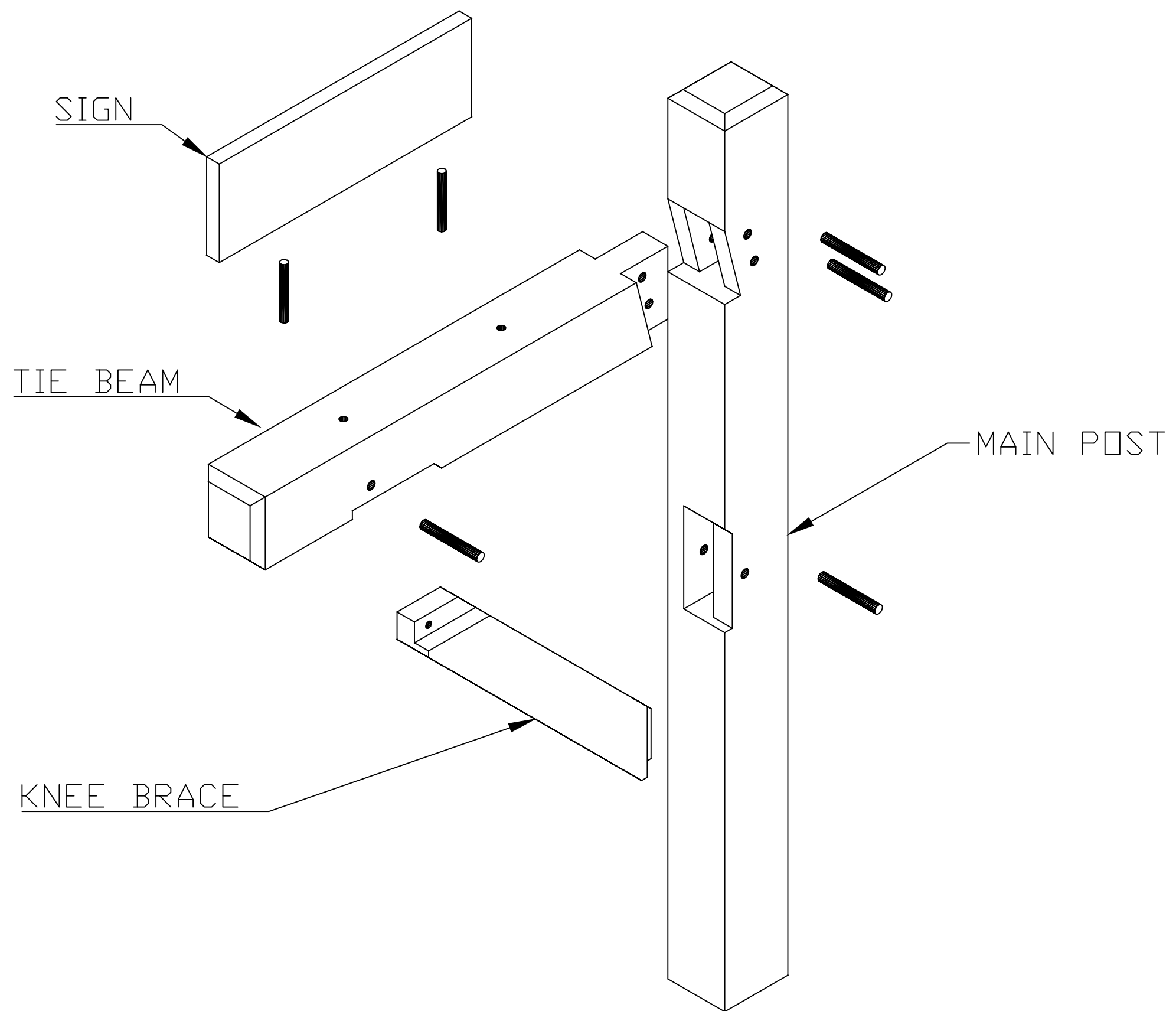

General Notes

1. MAIN POST 70X75 WOOD
TYPE TBA
2. TIE BEAM 70X75 WOOD
TYPE TBA
3. KNEE BRACE 50X75 WOOD
TYPE TBA
4. SIGN 20X100X300 WOOD
TYPE TBD

| No. | Revision/Issue | Date |
|-----|----------------|------|
| | | |
| | | |
| | | |



Project Name
SIGN POST

| | |
|----------------------------|--------------|
| Drawing EXPLODED | 2 of 4 |
| Date MARCH 2023 | |
| Scale 1:5 | |

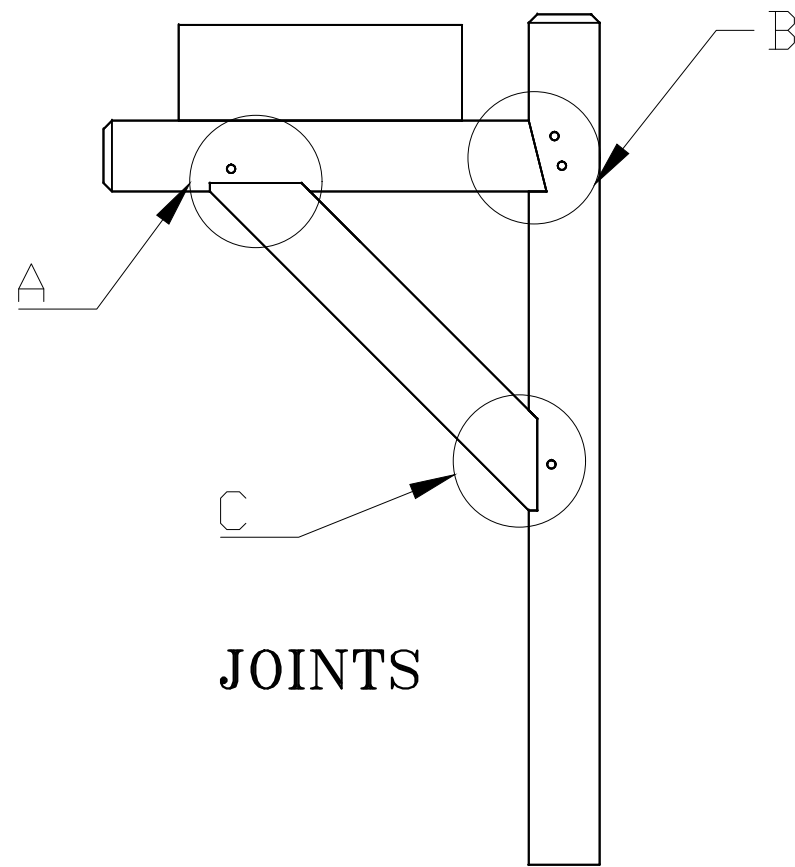

JOINTS

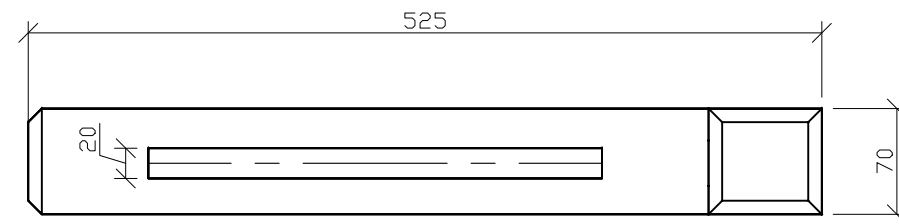

TOP

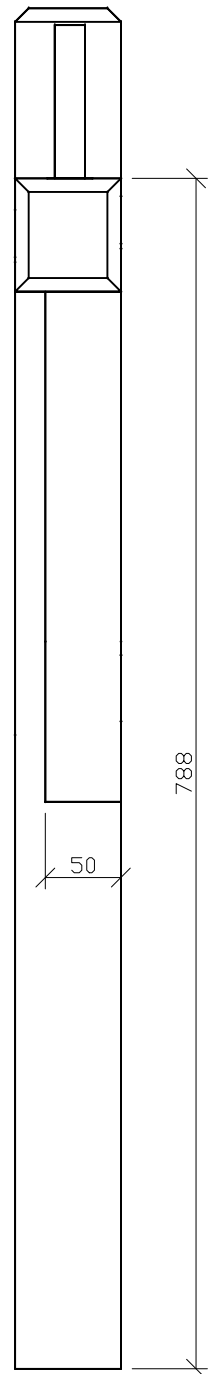

LEFT SIDE

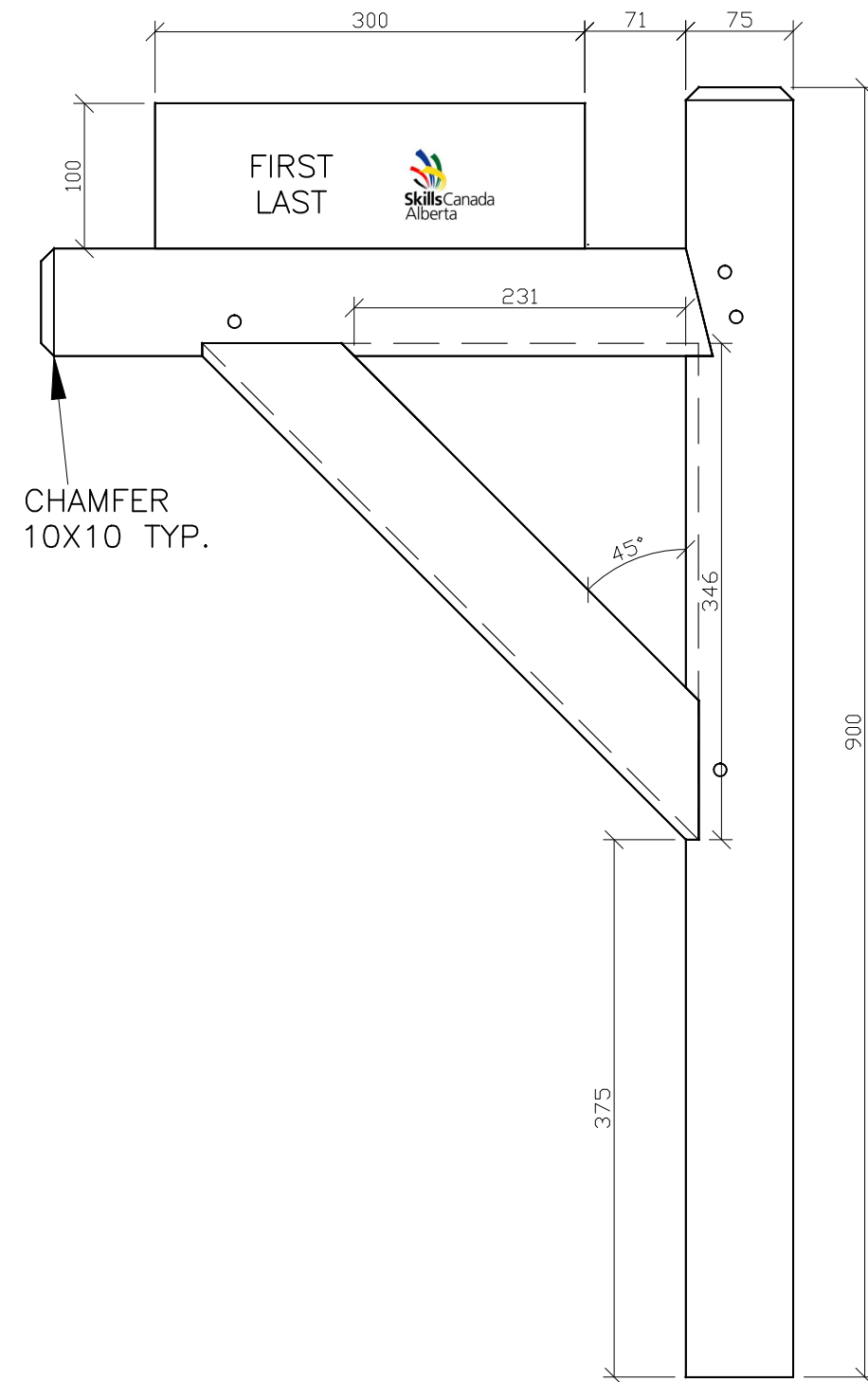

FRONT

General Notes

| No. | Revision/Issue | Date |
|-----|----------------|------|
| | | |
| | | |
| | | |



Project Name
SIGN POST

| | |
|--------------------------------|-------------------------------|
| Drawing ORTHOGRAPHIC | Sheet 3 of 4 |
| Date MARCH 2023 | |
| Scale 1:5 | |

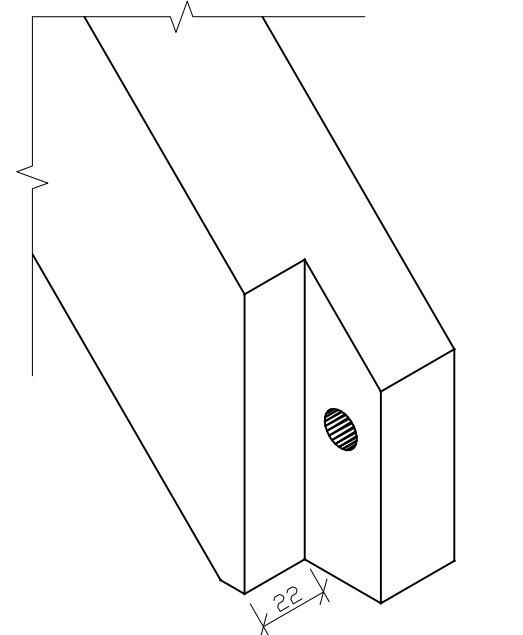
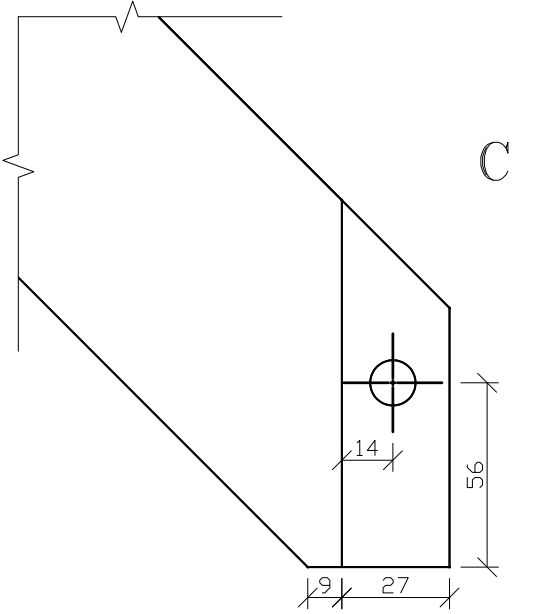
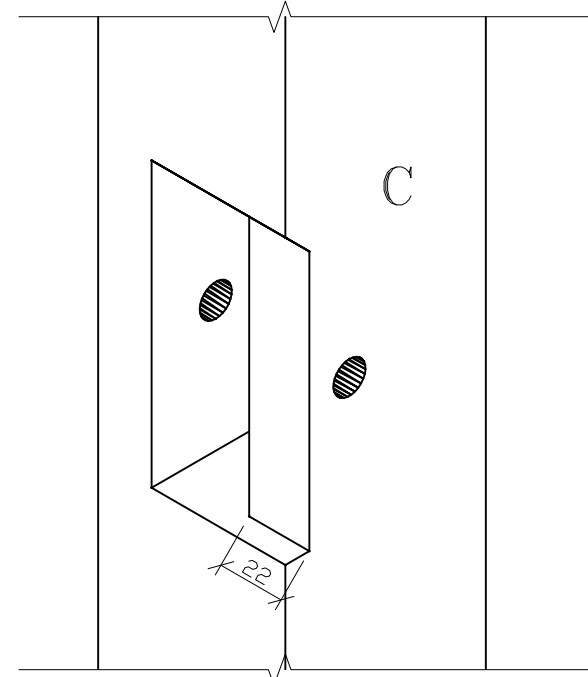
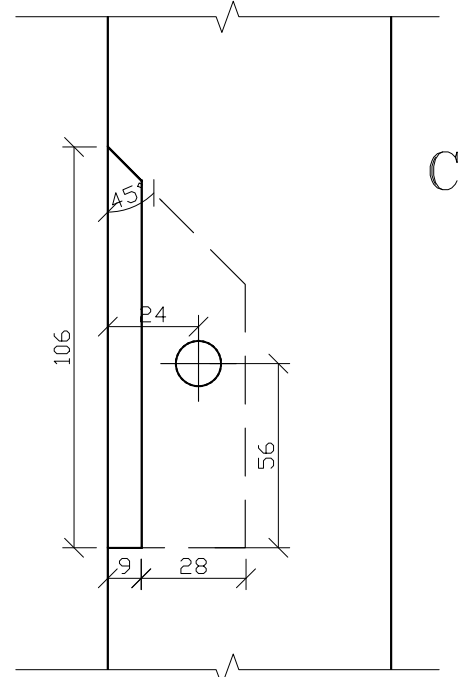
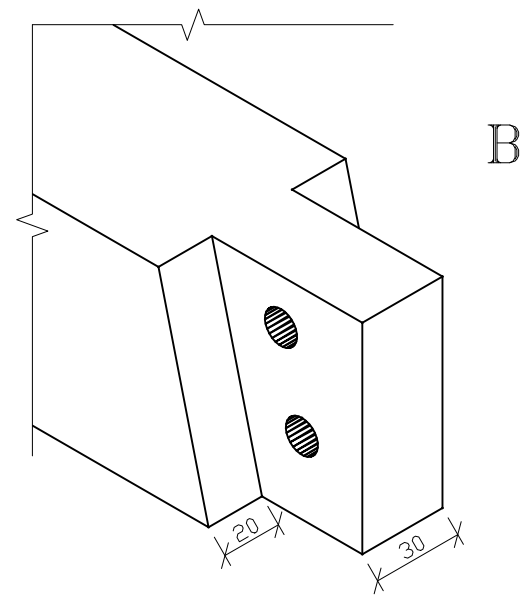
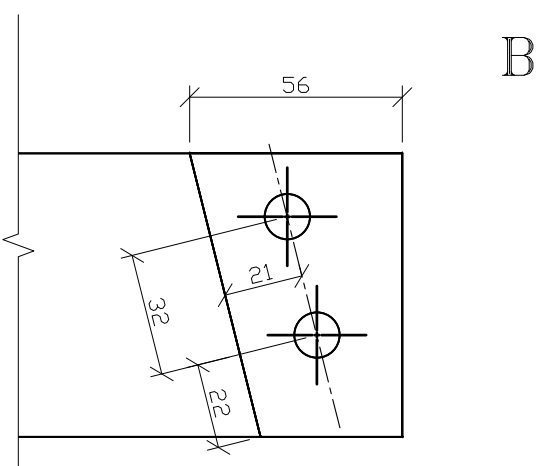
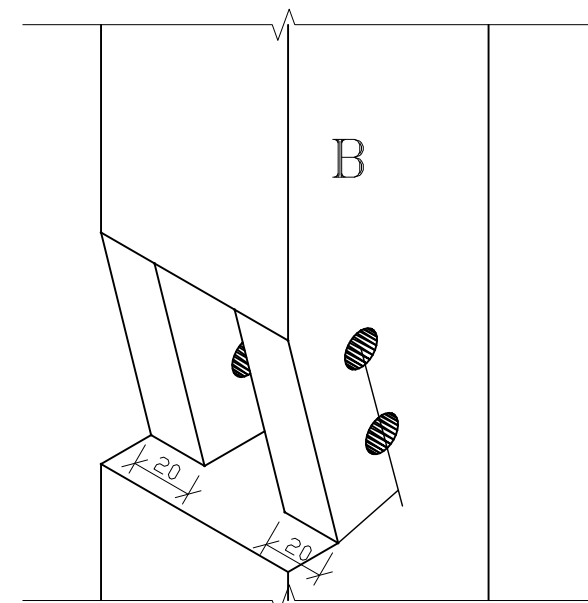
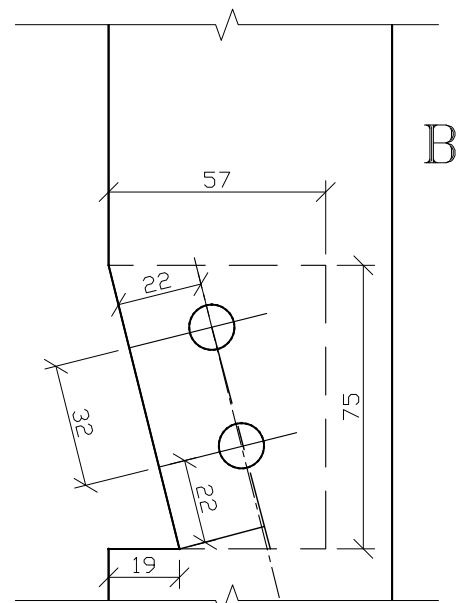
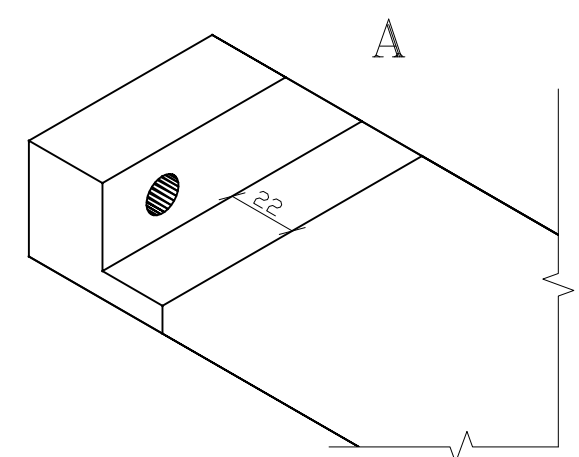
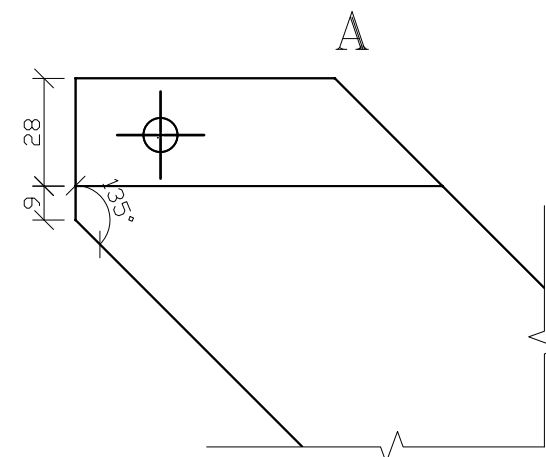
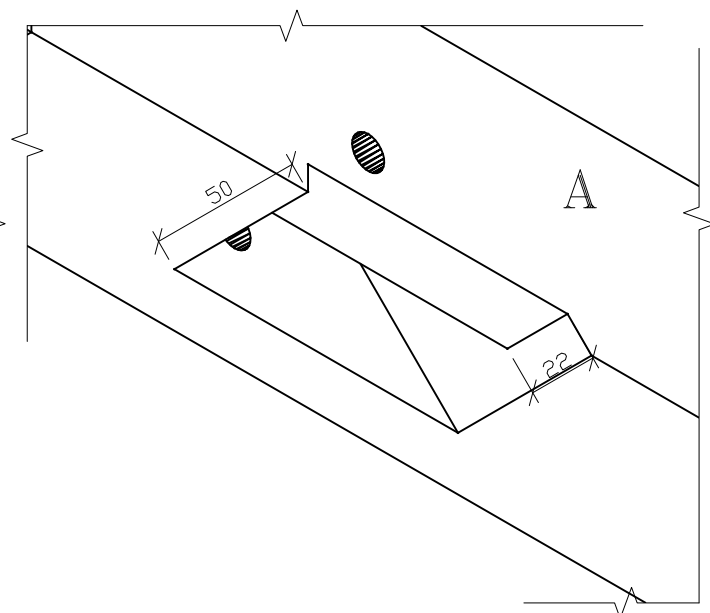
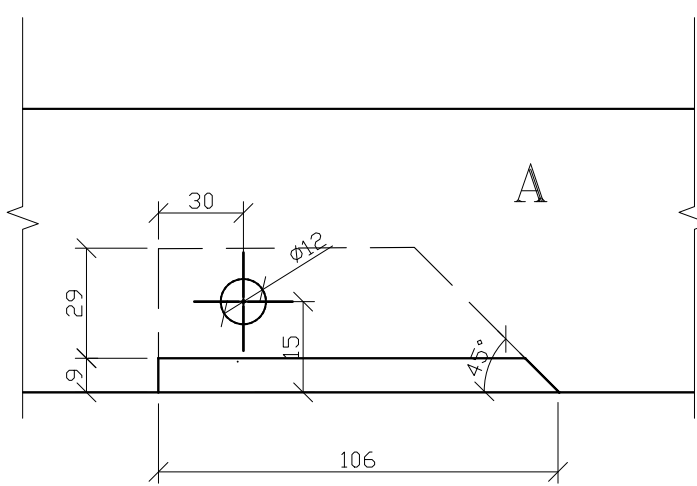

General Notes

1. ALL MORTISES OF THE JOINT SHOULD BE 1 TO 2 MM DEEPER THEN THE MEASUREMENT OF THE TENONS
2. DOWEL HOLES WILL BE DRILLED AFTER ASSEMBLY
3. ALL DOWEL HOLES ARE 1/2" DIAMETER
4. INDICATES MARKING POINT

| No. | Revision/Issue | Date |
|-----|----------------|------|
| | | |
| | | |
| | | |



Project Name
SIGN POST

| | |
|---------------------------|-------------------|
| Drawing JOINTS | Sheet 4 |
| Date MARCH 2023 | of 4 |
| Scale 1:2 | |