

4

3

2

1

ITEM	QTY / QTÉ	T / ÉP.	W / LARGEUR	L / LONGEUR	WT / POIDS TOTAL (kg)
A	1	9.53	242	285	5.16
B	1	9.53	110	235	1.93
C	1	9.53	110	150	1.23
D	1	9.53	100	200	1.50
E	1	9.53	80	200	1.20
F	1	9.53	130	150	1.46
G	1	9.53	115	130	1.12
H	1	9.53	130	200	1.95
J	1	9.53	100	240	1.80
K	1	9.53	130	240	2.33
L	1	9.53	164	200	2.45
M	1	6.35	95	95	0.45
N	1	9.53	185	235	3.25
P	1	9.53	130	135	1.31
Q	1	6.35	78	78	0.30
R	2	PIPE / TUYAU 89.1 (3" STD) x 50mm			2.49
S	2	RACCORD POUR POMPE/ESSAI			0.20
T	1	PIPE / TUYAU 89.1 (3" STD) x 227mm			5.65
				TOTAL:	30

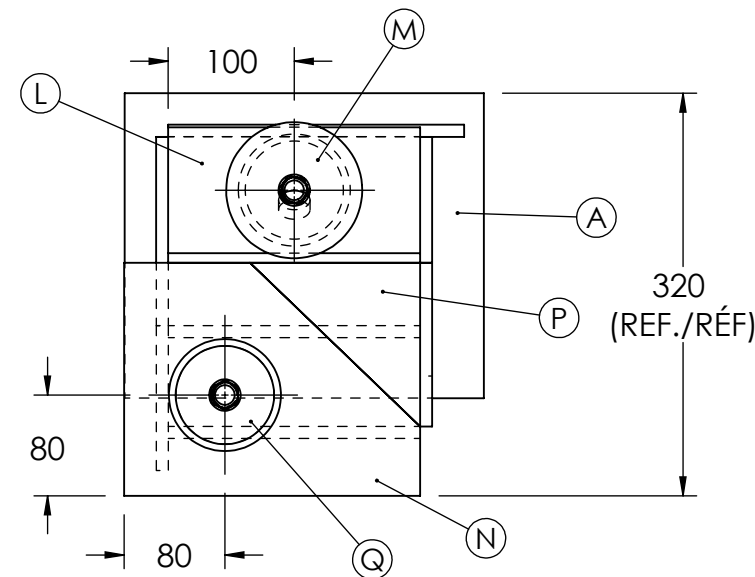

NOTE:

1. TACK WELD THE VESSEL SHOWN AND COMPLETELY SEAL ALL JOINTS USING THE WELDING PROCESSES LISTED.
2. ALL TACK WELDS SHALL BE ON THE OUTSIDE OF VESSEL WITH MAX. 15 mm IN LENGTH.
3. ALL WELDING TO CARRY OUT WITH BASE PLATE "A" IN THE FLAT POSITION.
4. ALL FILLET WELDS UNLESS NOTED OTHERWISE TO HAVE A LEG LENGTH OF 10 mm(+2.0/-0)
5. NO GRINDING TO TAKE PLACE AFTER THE FINAL CAP PASS HAS BEEN MADE.
6. SLAG REMOVAL AND POST CLEANING OF THE WELDS SHALL BE MADE USING WIRE BRUSH.

REMARQUE:

1. POINTEZ LE VAISSEAU ET SCELLEZ COMPLÈTEMENT TOUS LES JOINTS EN UTILISANT LES PROCÉDÉS DE SOUDAGE ÉNUMÉRÉS.
2. TOUTES LES SOUDURES DE POINTAGE DOIVENT ÊTRE EFFECTUÉES À L'EXTÉRIEUR DU VAISSEAU AVEC UN MAX.15 mm LONGUEUR.
3. TOUTES LES SOUDURES LA PLAQUE DE BASE "A" DOIVENT ÊTRE EFFECTUÉES EN POSITION PLATE.
4. TOUTES LES SOUDURES D'ANGLE SAUF INDICATION CONTRAIRE DOIVENT AVOIR UNE DIMENSION DE 10mm(+2.0/-0)
5. AUCUN MEULAGE PERMIS UNE FOIS LES PASSES DE FINITION EFFECTUÉES
6. L'ENLÈVEMENT DU LAITIER ET LE POST-NETTOYAGE DES SOUDURES DOIVENT ÊTRE RÉALISÉS À L'AIDE D'UNE BROSSE MÉTALLIQUE.

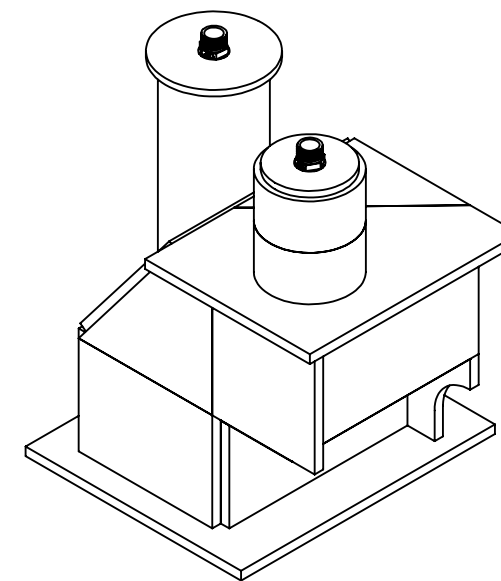
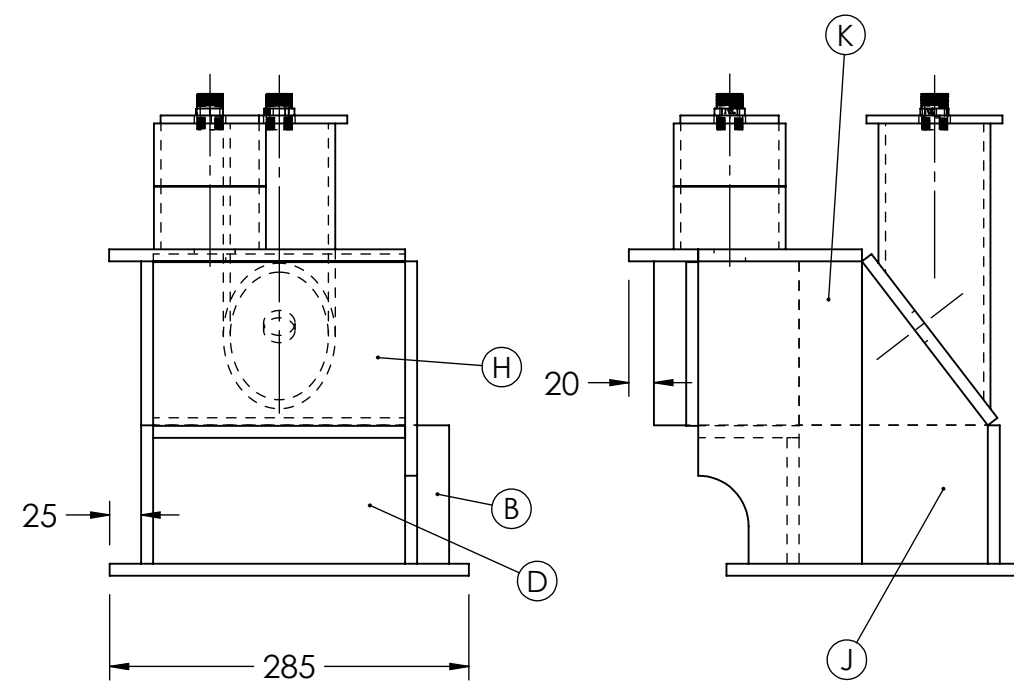
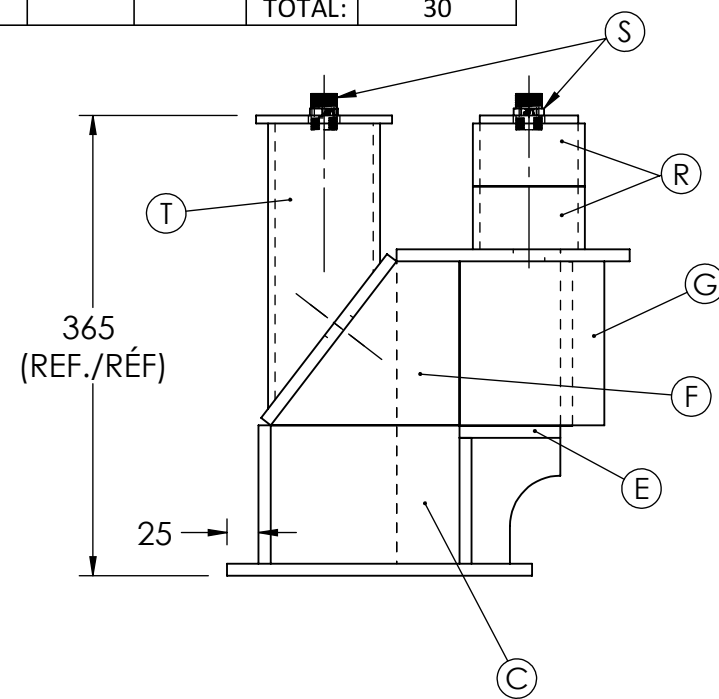

ISOMETRIC VIEW A / VUE ISOMÉTRIQUE A

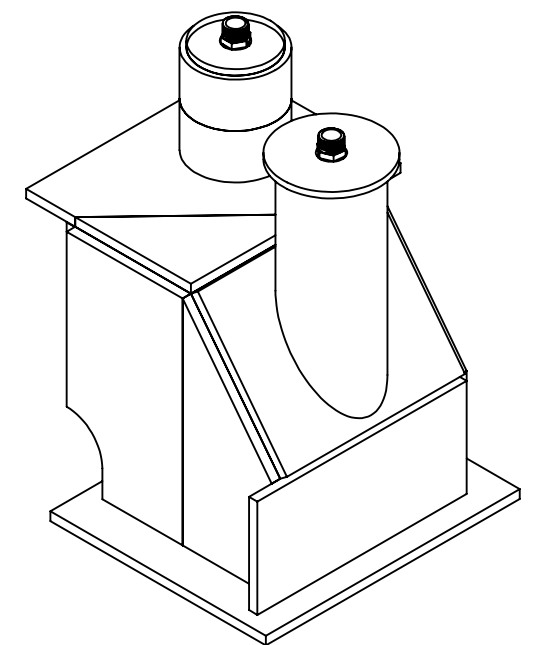

ISOMETRIC VIEW B / VUE ISOMÉTRIQUE B

ALL DIMENSIONS IN MILLIMETERS/TOUTES LES DIMENSIONS SONT EN MILLIMÈTRES



TITLE/TITRE: SCNC 2023 - POST-SECONDARY DAY 1 OCMT 2023 - POST-SECONDAIRE JOUR 1 WORLDS VESSEL / VAISSEAU SOUS PRESSION MONDIAL - ASSEMBLY / DESSIN D'ASSEMBLAGE		SHEET # NO. DE PAGE: 1 OF 3	SIZE/TAILLE: B
DWG. NO. / DESSIN NO.: SCC2023-PS1	REV.: 1	SCALE ÉCHELLE: 1:6	DESIGN/ CONCEPTION: DRAWN BY / DESSINÉ PAR: CHIH-PENG CHEN J. HYDE 2022-12-21

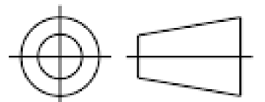

4

3

2

1

4

3

2

1

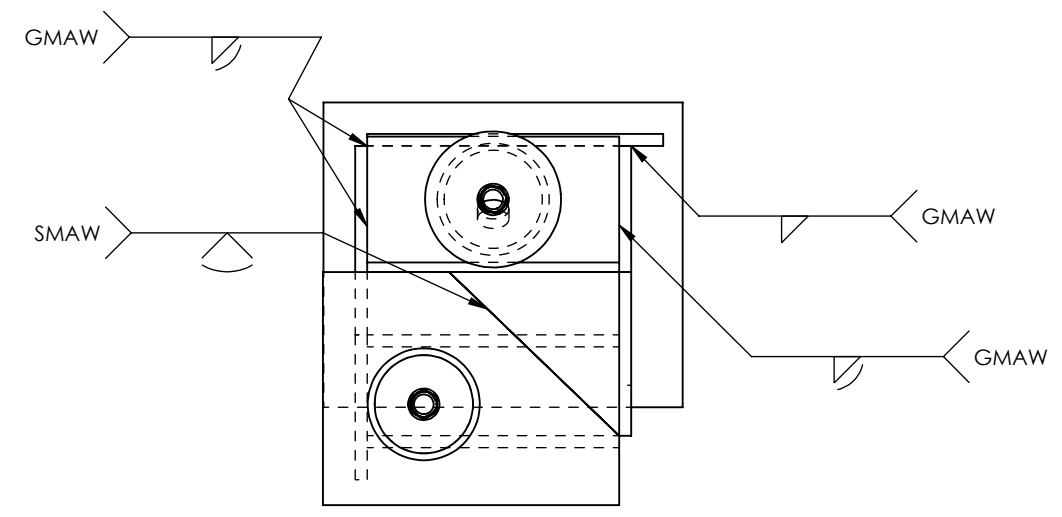

NOTE:
 1. TACK WELD THE VESSEL SHOWN AND COMPLETELY SEAL ALL JOINTS USING THE WELDING PROCESSES LISTED.
 2. ALL TACK WELDS SHALL BE ON THE OUTSIDE OF VESSEL WITH MAX. 15 mm IN LENGTH.
 3. ALL WELDING TO CARRY OUT WITH BASE PLATE "A" IN THE FLAT POSITION.
 4. ALL FILLET WELDS UNLESS NOTED OTHERWISE TO HAVE A LEG LENGTH OF 10 mm(+2.0/-0)
 5. NO GRINDING TO TAKE PLACE AFTER THE FINAL CAP PASS HAS BEEN MADE.
 6. SLAG REMOVAL AND POST CLEANING OF THE WELDS SHALL BE MADE USING WIRE BRUSH.

REMARQUE:
 1. POINTEZ LE VAISSEAU ET SCELLEZ COMPLÈTEMENT TOUS LES JOINTS EN UTILISANT LES PROCÉDÉS DE SOUDAGE ÉNUMÉRÉS.
 2. TOUTES LES SOUDURES DE POINTAGE DOIVENT ÊTRE EFFECTUÉES À L'EXTÉRIEUR DU VAISSEAU AVEC UN MAX.15 mm LONGUEUR.
 3. TOUTES LES SOUDURES LA PLAQUE DE BASE "A" DOIVENT ÊTRE EFFECTUÉES EN POSITION PLATE.
 4. TOUTES LES SOUDURES D'ANGLE SAUF INDICATION CONTRAIRE DOIVENT AVOIR UNE DIMENSION DE 10mm(+2.0/-0)
 5. AUCUN MEULAGE PERMIS UNE FOIS LES PASSES DE FINITION EFFECTUÉES
 6. L'ENLÈVEMENT DU LAITIER ET LE POST-NETTOYAGE DES SOUDURES DOIVENT ÊTRE RÉALISÉS À L'AIDE D'UNE BROUSSE MÉTALLIQUE.

B

B

A

A

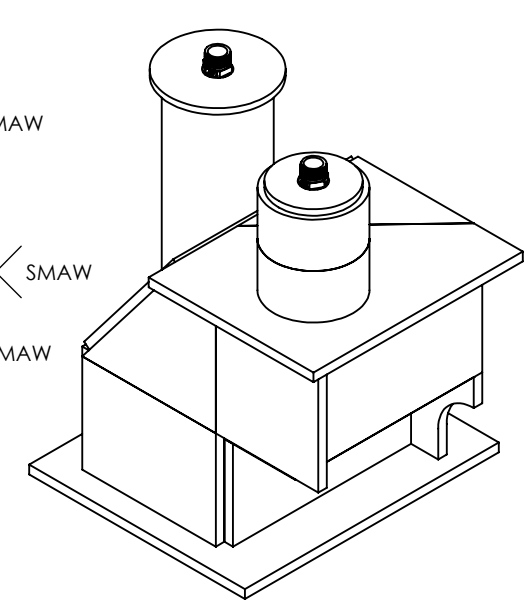
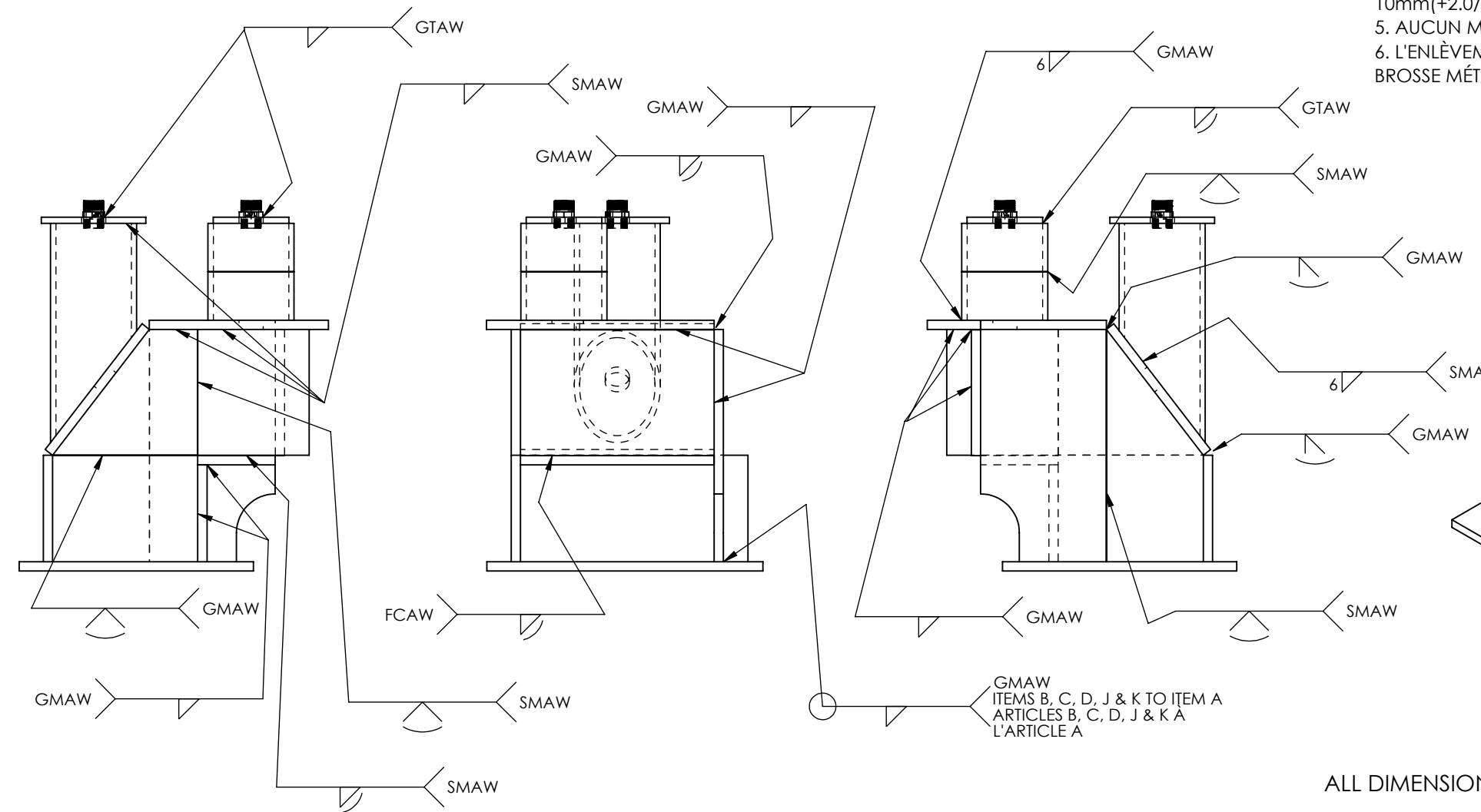

ISOMETRIC VIEW A /
VUE ISOMÉTRIQUE A

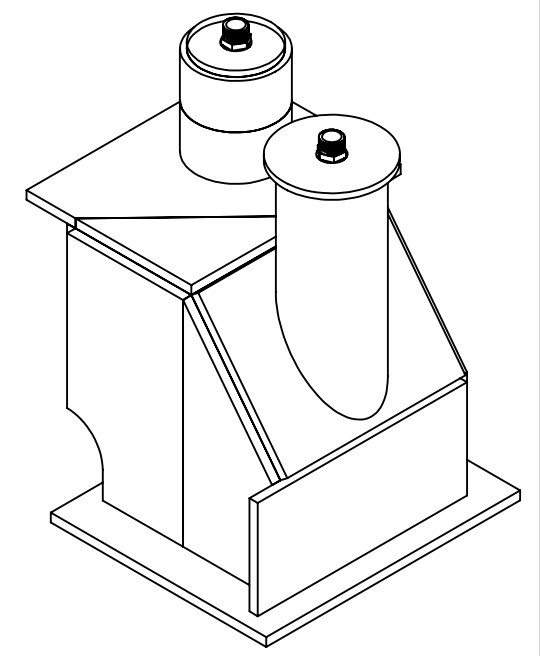

ISOMETRIC VIEW B /
VUE ISOMÉTRIQUE B

ALL DIMENSIONS IN MILLIMETERS/TOUTES LES DIMENSIONS SONT EN MILLIMÈTRES

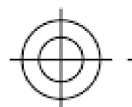
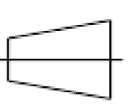

TITLE/TITRE: SCNC 2023 - POST-SECONDARY DAY 1 OCMT 2023 - POST-SECONDAIRE JOUR 1 WORLDS VESSEL / CUVE SOUS PRESSION MONDIALE - WELDS / SOUDAGE			SHEET # NO. DE PAGE: 2 OF 3	SIZE/TAILLE: B
DWG. NO. / DESSIN NO.: SCC2023-PS1	REV.: 1	SCALE ÉCHELLE: 1:6	DESIGN/ CONCEPTION: DRAWN BY / DESSINÉ PAR: CHIH-PENG CHEN J. HYDE 2022-12-21	 

4

3

2

1

4

3

2

1

B

B

A

A

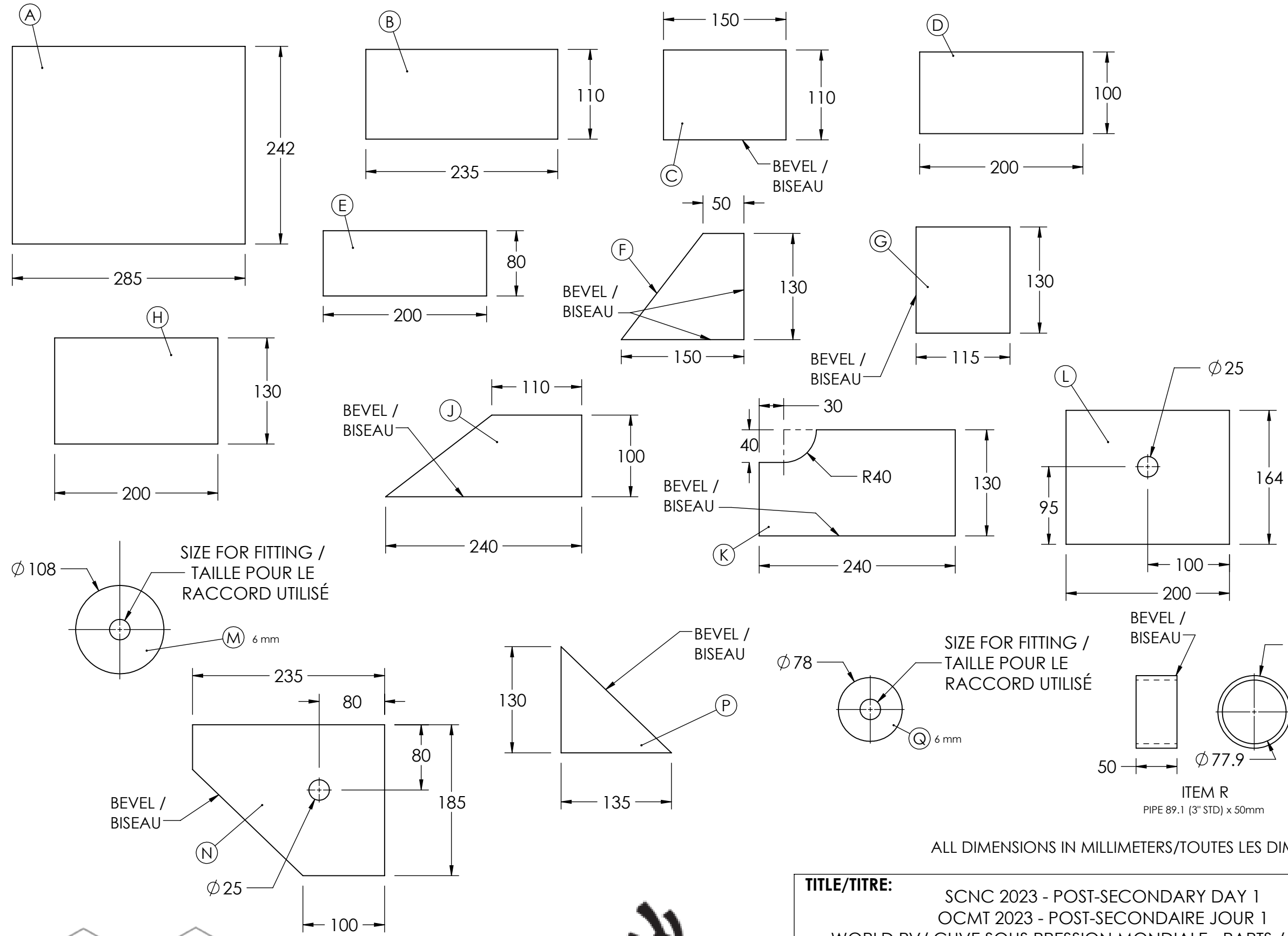

ITEM	QTY / QTÉ	T / ÉP.	W / LARGEUR	L / LONGUEUR	WT / POIDS TOTAL (kg)
A	1	9.53	242	285	5.16
B	1	9.53	110	235	1.93
C	1	9.53	110	150	1.23
D	1	9.53	100	200	1.50
E	1	9.53	80	200	1.20
F	1	9.53	130	150	1.46
G	1	9.53	115	130	1.12
H	1	9.53	130	200	1.95
J	1	9.53	100	240	1.80
K	1	9.53	130	240	2.33
L	1	9.53	164	200	2.45
M	1	6.35	95	95	0.45
N	1	9.53	185	235	3.25
P	1	9.53	130	135	1.31
Q	1	6.35	78	78	0.30
R	2	PIPE / TUYAU 89.1 (3" STD) x 50mm			2.49
S	2	RACCORD POUR POMPE D'ESSAI			0.20
T	1	PIPE / TUYAU 89.1 (3" STD) x 227mm			5.65
TOTAL:					30

ALL DIMENSIONS IN MILLIMETERS/TOUTES LES DIMENSIONS SONT EN MILLIMÈTRES

TITLE/TITRE: SCNC 2023 - POST-SECONDARY DAY 1 OCMT 2023 - POST-SECONDAIRE JOUR 1 WORLD PV/ CUVE SOUS PRESSION MONDIALE - PARTS / LES PIÈCES			SHEET # NO. DE PAGE: 3 OF 3	SIZE/TAILLE: B
DWG. NO. / DESSIN NO.: SCC2023-PS1	REV.: 1	SCALE ÉCHELLE: 1:5	DESIGN/ CONCEPTION: DRAWN BY / DESSINÉ PAR: CHIH-PENG CHEN J. HYDE	DATE: 2022-12-21

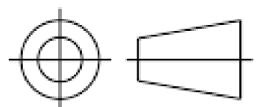

4

3

2

1