



2023 Regional Skills Canada Competition



2023 Central Regional Skills Canada Competition

Contest Description (Scope Document)

Location: Red Deer Polytechnic

March 18, 2023

EVENT: Carpentry	LEVEL: Secondary										
DURATION OF CONTEST: 5.5 HOURS	LOCATION: ROOM 804, RED DEER POLYTECHNIC										
COMPETITION SCHEDULE: <table border="1"> <tr> <td>REGISTRATION</td> <td>7:30 AM – 8:00 AM</td> </tr> <tr> <td>ORIENTATION</td> <td>8:00 AM – 8:30 AM</td> </tr> <tr> <td>COMPETITION</td> <td>8:30 AM – 11:15</td> </tr> <tr> <td>LUNCH</td> <td>11:15 – 12:00 PM</td> </tr> <tr> <td>COMPETITION</td> <td>12:00 PM – 2:45 PM</td> </tr> </table>	REGISTRATION	7:30 AM – 8:00 AM	ORIENTATION	8:00 AM – 8:30 AM	COMPETITION	8:30 AM – 11:15	LUNCH	11:15 – 12:00 PM	COMPETITION	12:00 PM – 2:45 PM	REGIONALIZED: YES If YES, To compete at the Provincial Skills Canada Competition students must qualify at their Regional Skills Canada Competition.
REGISTRATION	7:30 AM – 8:00 AM										
ORIENTATION	8:00 AM – 8:30 AM										
COMPETITION	8:30 AM – 11:15										
LUNCH	11:15 – 12:00 PM										
COMPETITION	12:00 PM – 2:45 PM										
AWARDS CEREMONY INFORMATION: in Margaret Parsons Theatre (Room 1400) at approx. 4:00PM.											

CONTEST INTRODUCTION

- To evaluate each contestant’s competency to organize and execute a given work assignment accurately and safely in the carpenter trade.
- To recognize outstanding excellence and professionalism.

SKILLS AND KNOWLEDGE TO BE TESTED

- Demonstrate skills and competency in interpreting prints, shop drawings, and specifications.
- Demonstrate the safe use of hand and power tools.
- Demonstrate acceptable site management, housekeeping, and best practices.
- Proficient knowledge and demonstration of skill in; framing, cutting and drilling materials, fastening techniques, joinery, determining angles & elevations, trim & finishing.
- Quality, accuracy and thoroughness of workmanship.
- Ability to complete an assignment within a specified time frame.



2023 Regional Skills Canada Competition



PROJECT DESCRIPTION

Please see the attached practice plans released along with the contest description in addition to this isometric image. On the day of the Regional Competition, competitors will be provided the actual Competition Plans which may have been changed up to 30% from the practice set.

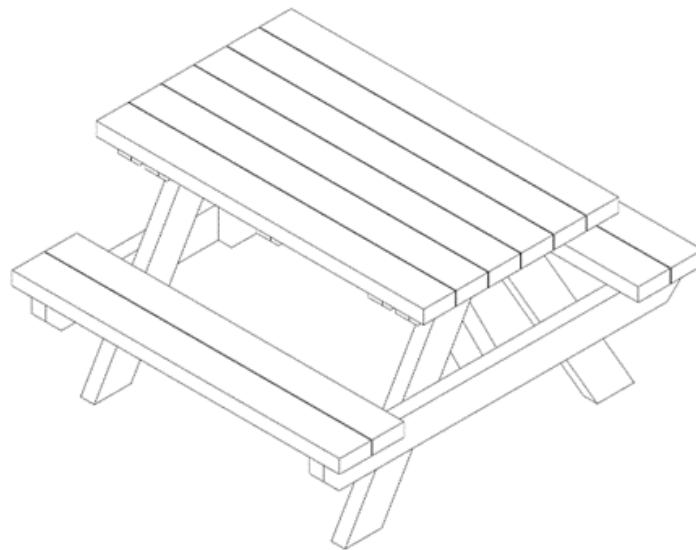

PICNIC TABLE



2023 Regional Skills Canada Competition



EQUIPMENT & MATERIALS

Equipment and Materials Competitors Must Supply:

Measuring/Layout	Safety	Assembly Tools	Misc.
Pencils	CSA Approved Footwear (green triangle standard), Eyewear and Hard Hat (Loaners will be available)	Hammer / Mallet	Non-Programmable Calculator
Metric Tape Measure		Screwdriver (Rob #2)	Carpenters Apron
Framing Square			2 – 12" Quick Clamps (minimum)
Speed Square	Cutting Tools	Disassembly Tools	
Combination Square	10-12 Point Cross-cut Hand Saw	Examples:	
Sliding T-Bevel	Wood Chisels	Glazing Bar	
Stair Gauges	Utility Knife -not Olfa style	Nail Claw	
Chalk Line	Block and /or Smooth Plane	Wonder Bar	

Equipment and Materials Supplied by the Committee:

All materials and fasteners will be provided for the project

Power Tools And Equipment		Safety
Cordless Drill	Saw Horses	Dust Masks
Cordless Impact Driver	Drill Bits	CSA approved hearing protection
Cordless Jigsaw	Driver Bits	First Aid Station
Cordless Circular Saw	Clamps over 12"	Water Station
Sanding Blocks	Sandpaper (100 Grit)	

*** No additional home-made jigs or gauges, power tools or power tools accessories will be allowed during the competition.**

*** Any tool or equipment not contained in the scope will be inspected and approved/removed by committee member.**

***NO personal electronic data devices (cell phones, smartphones, tablets, etc.) will be allowed in the competition area.**

SAFETY

The health, safety and welfare of all individuals involved with Skills Canada Alberta are of vital importance. Safety is a condition of participation with Skills Canada Alberta and shall not be sacrificed for the sake of expediency. At the discretion of the judges and technical committees, any competitor can be denied the right to participate should they not have the required proper safety equipment and/or act in an unsafe manner that can cause harm to themselves or others.



2023 Regional Skills Canada Competition



It is important that competitors present a professional image and appearance. Appropriate work clothing must be worn to compete. All clothing must be neat and clean and free of rips and tears. Casual wear such as shorts will not be permitted. No loose fitting clothes or jewelry.

Safety Requirements: MANDATORY

- CSA approved footwear – green triangle standard (Competitor)
- CSA approved hard hat (Loaners available from Committee)
- CSA approved safety glasses (Loaners available from Committee)
Prescription glasses must conform to CSA regulations. (Competitor)
- CSA approved hearing protection (Provided by Committee)
- Suitable work clothing (Competitor)
- Competitors are required to follow all industry safety standards during the competition.

JUDGING CRITERIA

• SAFETY/CLEAN-UP	15%
• DIMENSIONS	30%
• CONSTRUCTION	35%
• SALABILITY	10%
• MATERIAL USAGE	10%
OVERALL TOTAL	100%

TIE BREAKING PROCESS

If two or more participants are tied in points at the end of the competition, the following tie breaking procedure will be used:

- Step 1.** Participant with the highest Safety score.
- Step 2.** Participant who has completed the project in the least amount of time.
- Step 3.** Re-evaluate the projects with different judges.

RELATED CAREER AND TECHNOLOGY STUDIES COURSES

Descriptions of all modules are located at the following website:

https://education.alberta.ca/media/160534/con_course_summaries_old.pdf

- CRA 3407 HAND TOOLS THEORY
- CRA 3417 PORTABLE POWER TOOLS
- CRA 3452 SKETCHING & DRAWINGS
- CRA 3457 DRAWING PRINCIPLES
- CON 1010 CONSTRUCTION TOOLS AND MATERIALS
- CON 1070 BUILDING CONSTRUCTION
- CON 1120 PRODUCT MANAGEMENT



2023 Regional Skills Canada Competition



- CON 1130 SOLID STOCK CONSTRUCTION
- CON 2035 FRAMING SYSTEMS - FLOOR
- CON 2045 FRAMING SYSTEMS – WALL
- CON 2050 ROOF STRUCTURES 1

ADDITIONAL INFORMATION

Lunch will be provided for all competitors. Unfortunately, all allergies may not be able to be accommodated for. Please connect with the local Regional Coordinator for more information.

Regulations & Policies: A copy of the Skills Canada Alberta Regional Regulations & Policies can be found at the following link: <https://skillsalberta.com/policies-and-procedures>

LOCAL REGIONAL COMPETITION COMMITTEE MEMBERS

Dwayne Rausch	
Larz Hirschhorn	
Gary Halvorson	

PROVINCIAL TECHNICAL COMMITTEE MEMBERS

Gary Halvorson – Chair, Infrastructure	John Wilkinson - Lakeland
Paul Bettio – Co-Chair, NTC Rep, Judge Coordinator	James Kovesy - Nait
Hunter Shaw – Secretary, Safety Lead	Jordan Kalczak - Lakeland
Tony Lovell – Co-Safety	Kevin McKinley - Nait
Dwayne Rausch – Regional Project Lead	Tyrel Churko - Lethbridge
Alan Kabotoff – Secondary Project Lead	Shawn Scotney - Lethbridge
Curtis Cassibo – Co-Secondary Project Lead	
Ron Bolokoski – Post-Secondary Project Lead	
Larz Hirschhorn – Orientation Facilitator Lead	
Rod Woloschuk – Co-Orientation Facilitator	
Joe Pipke – Try-a-Trade Coordinator	
Kim Letwin – Try-a-Trade Coordinator	
Kevin MacKenzie – High School Liaison	
Michael Androschuk - Exploration Day Lead	
Daniel Vervloet – Industry Liaison	