

Notes:
- All dimensions are in millimeters

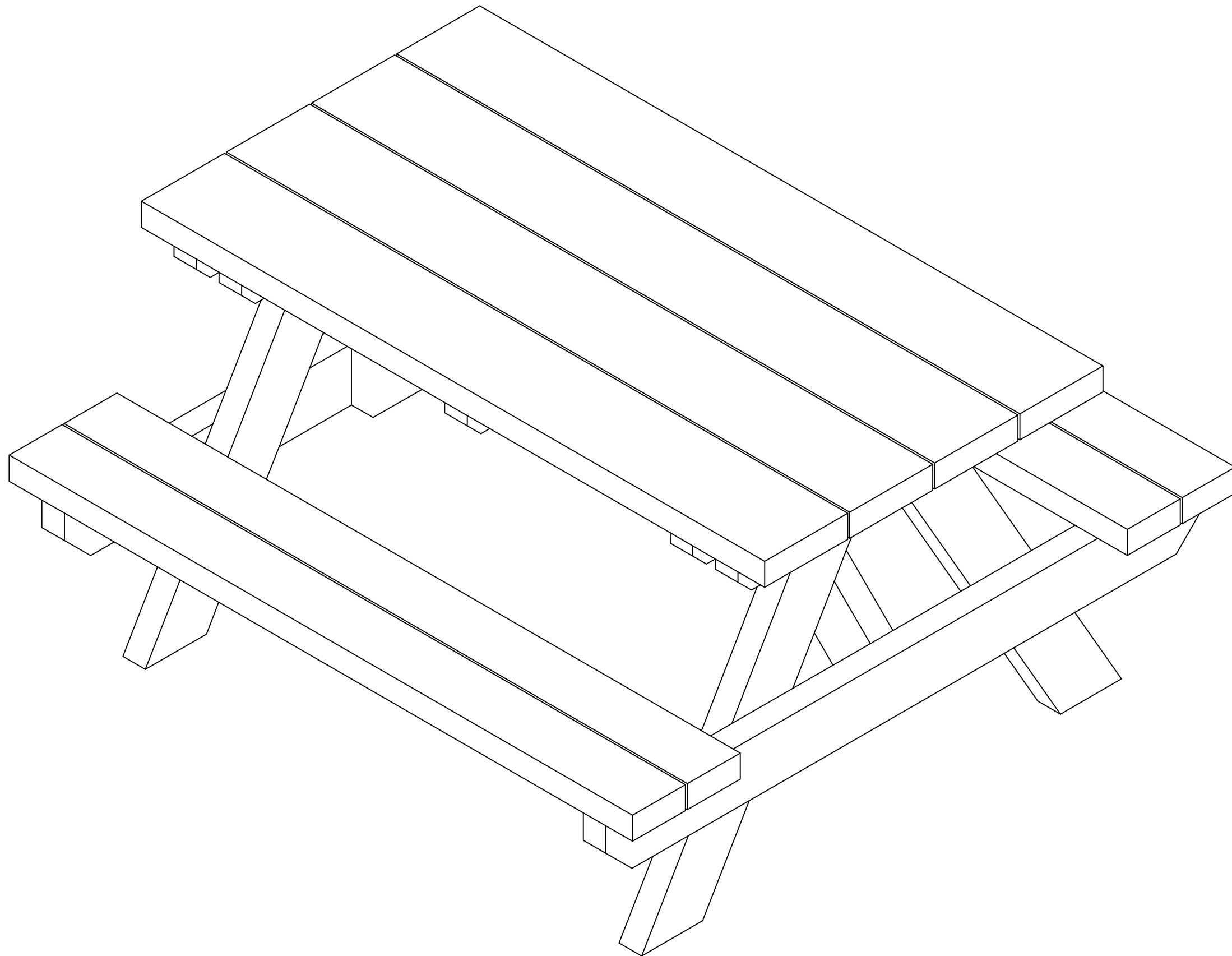

Revised:



Regional Skills
Picnic Table
Isometric

Drawn: jht
Date: February 2023
Scale: not to scale (n.t.s.)

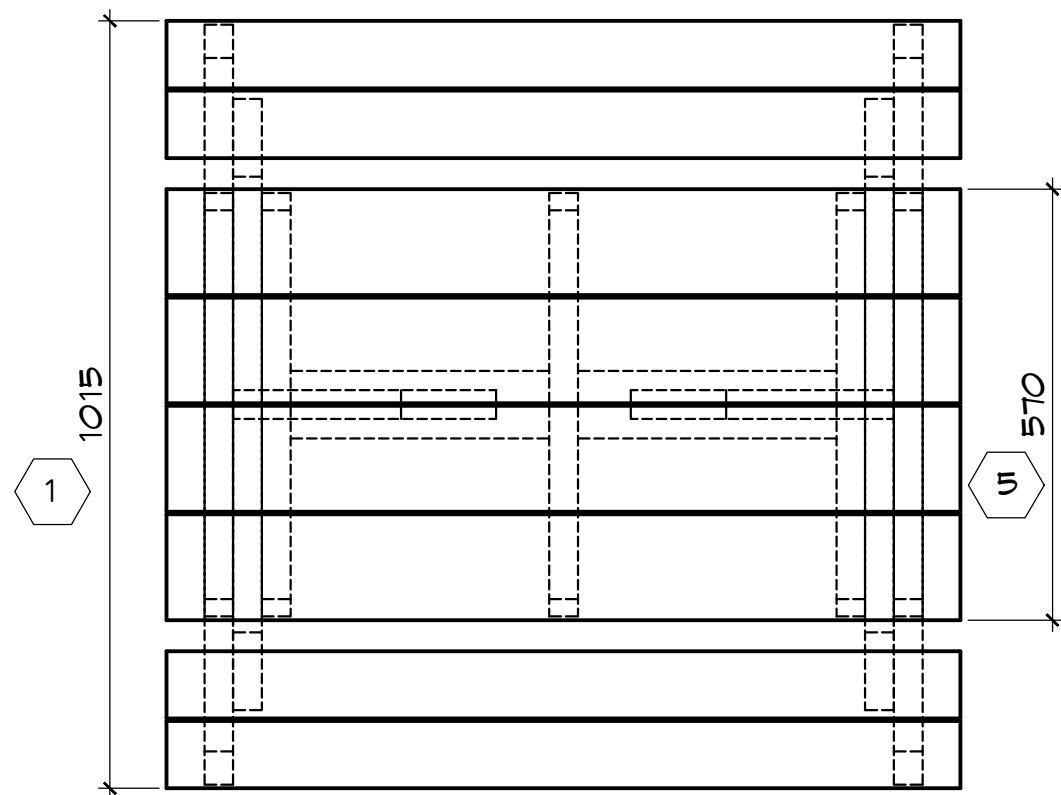

Top View

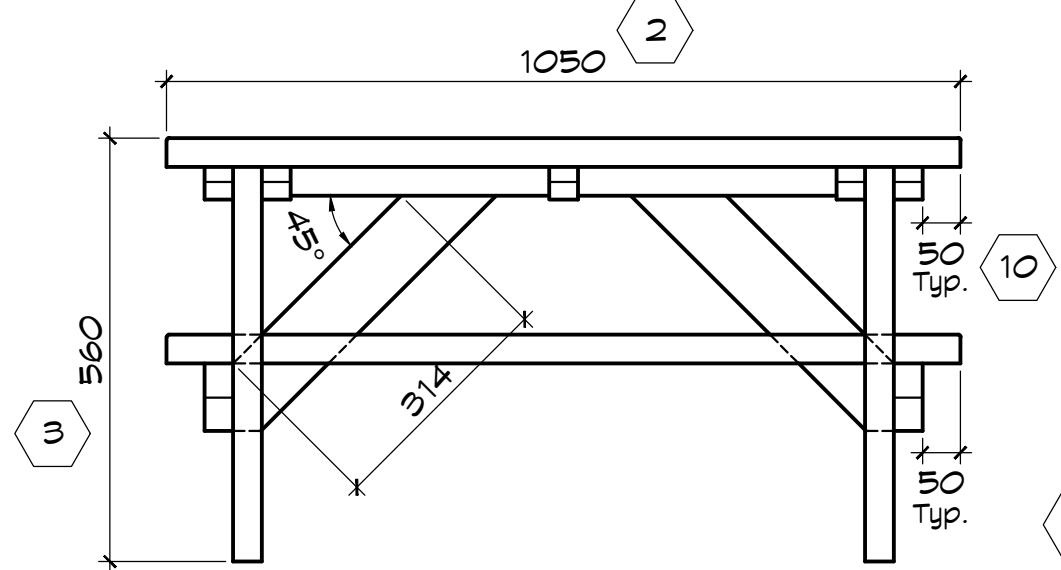

Front View

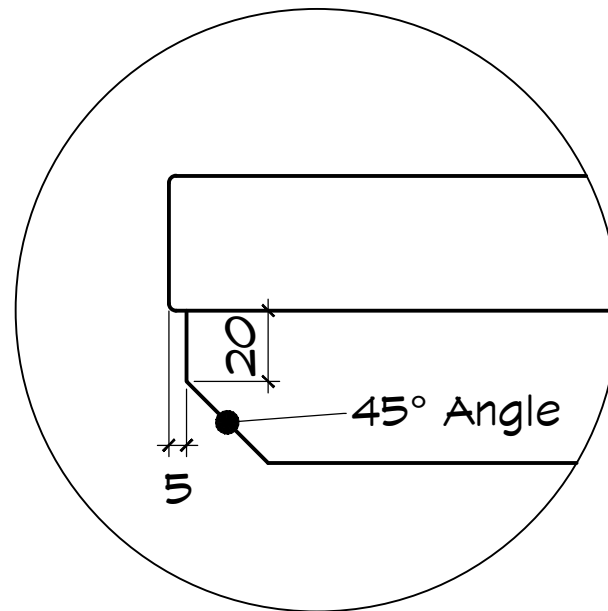

Detail A
n.t.s.

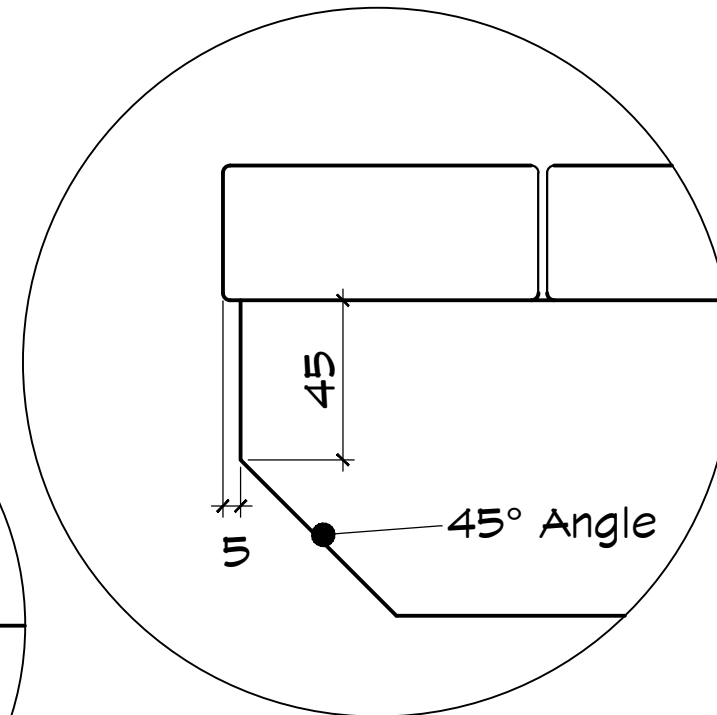

Detail B
n.t.s.

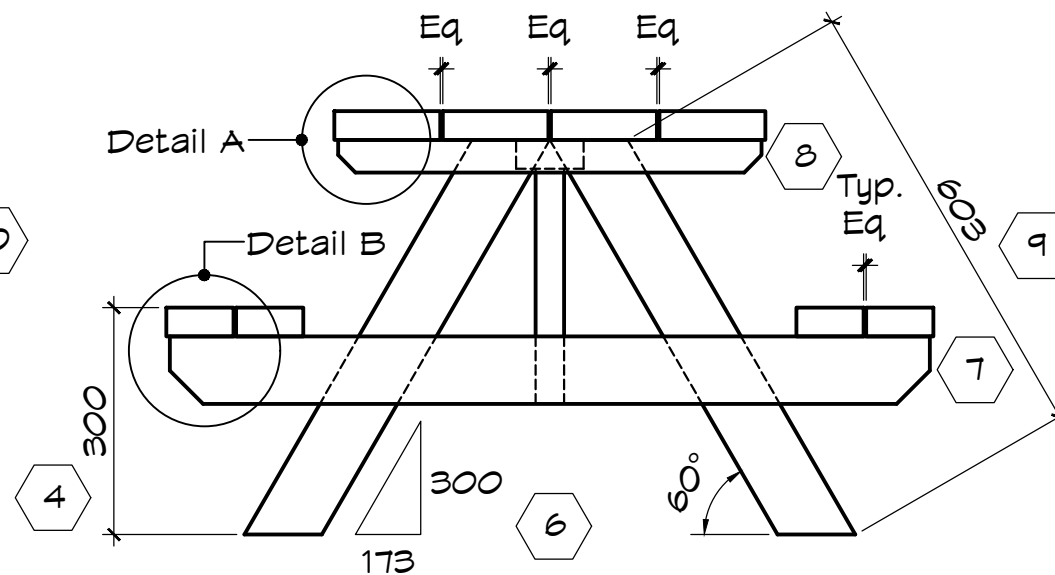

Side View

Notes:

- All dimensions are in millimeters
- 38 x 140 = Top
- 38 x 89 = Legs, cross-supports, blocking, angled braces and seat
- 38 x +/- 43 = cleats below top
- All material to be fastened with 2 - 2 1/2" deck screws per joint except cross-support to each leg which requires 3 screws.
- Screw heads to be flush with material
- Fasten cleats to the top pieces from below so that screws are not exposed.
- Any increment of 173 over 300 (using a metric framing square) can be used to obtain a 30° angle cut on the table legs.
- All cut edges to be eased
- ⬡ denotes marking criteria

Revised:



Regional Skills
Picnic Table
Elevations & Details

Drawn: jht
Date: February 2023
Scale: 1:10