

127(
 † \$// 0\$7(5,\$/ 0,/' 67((/ 3/\$7(
 † 7\$&. :(/' (17,5(\$66(0%/< \$77\$,1 67\$03)520 &200,77((\$1' 21/< 7+(1 %(*,1 :(/',1*
 † \$// :(/',1* 0867 %('21(: ,7+ %\$6(3/\$7(\$ 6,77,1*)/\$7 21 7\$%/(
 † *\$3 \$1' 5227)\$&()25 35(3\$5(' 9((*5229(:(/'6 ! <285 &+2,&(
 † \$// 9(57,&\$/ :(/',1* 72 %('21(,1 83+ ,// 352*5(66,21

5(0\$548(6
 † 7287 /(0\$7e5,(/ (67 (1 \$&,(5 '28;
 † 628' (= 3\$5 32,17\$*(7287 / \$66(0%/\$*(2%7(1(= /(32,1d21 '8 &20,7e \$9\$17&200(1&(
 † /\$ 3/\$48('.\$66,6(© \$ ^ '2,7 È75(- 3/\$7 685 /\$ 7\$%/('85\$17 7287(6 /(6 \$&7,9,7e6 '(
 † (63\$&(0(17 (7 (&\$57(0(17 3285 /(6 628'85(6 (1 9 ! - 9275(&+2,;
 † 7287(6 /(6 628'85(6 9(57,&\$/(6 '2,9(17 È75((;e&87e(6 (1 0217\$17

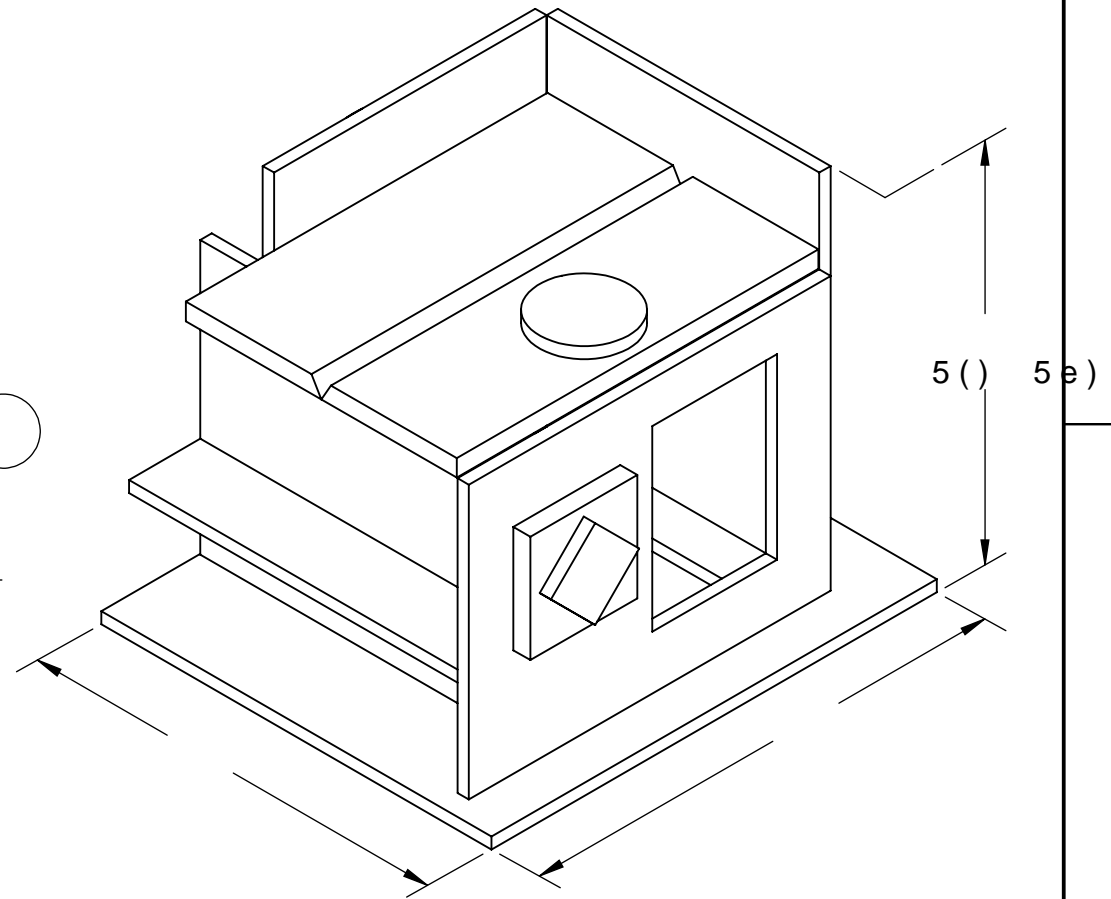
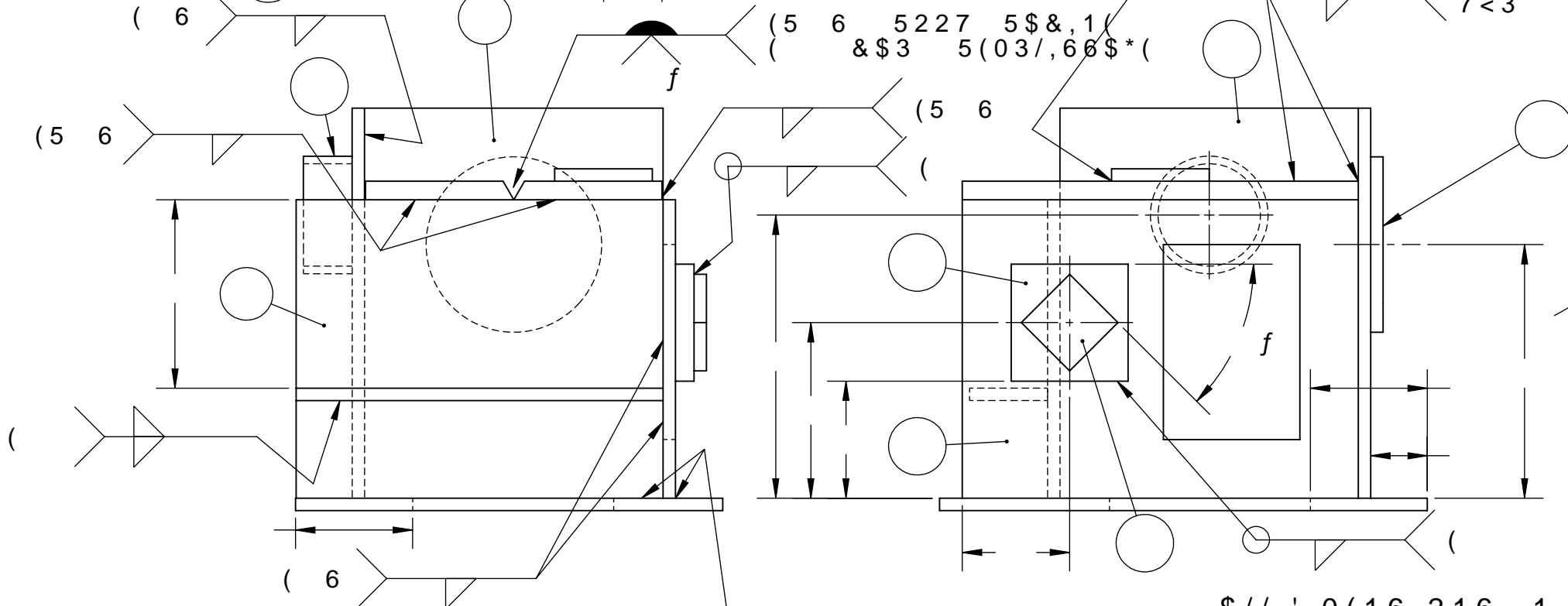

\$// 3&6 72 \$
 7287(6 /(6
 3,È&(6 \$

\$// ',0(16,216 ,1 0,//,0(7(56 7287(6 /(6 ',0(16,216 6217 (1 0

7,7/(PSCC	6(&21'\$5< '\$<	6+((7 12 '(3\$*(6,=(7\$,//(
		:25/' 9(66(2)	%
' : * 12	5(9	6&\$/(e&+((//('\$7('5\$:1 %< - +<'('\$7(
6 & 1 & 6				

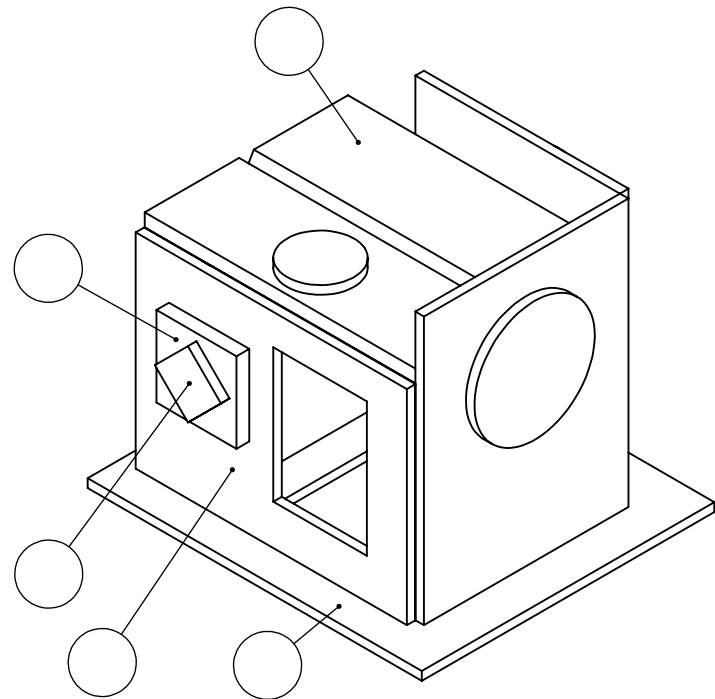

,620(75,& 9,(: %
98(,620<75,48(%

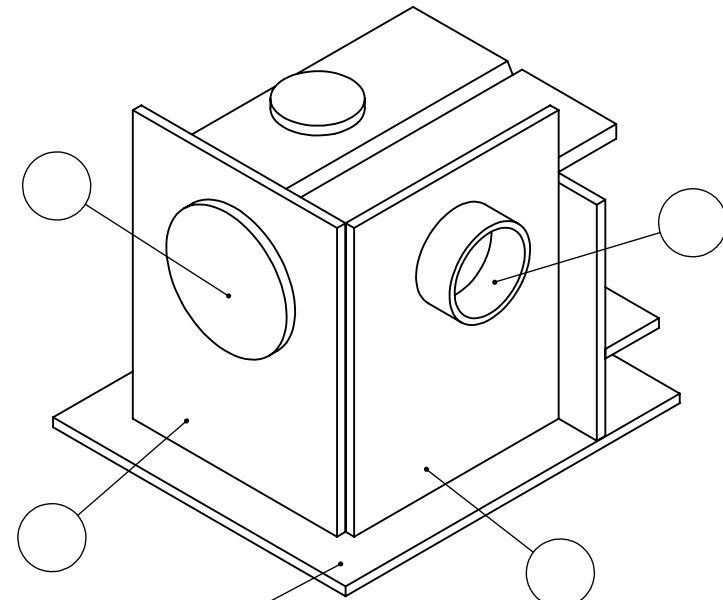

,620(75,& 9,(: &
98(,620<75,48(&

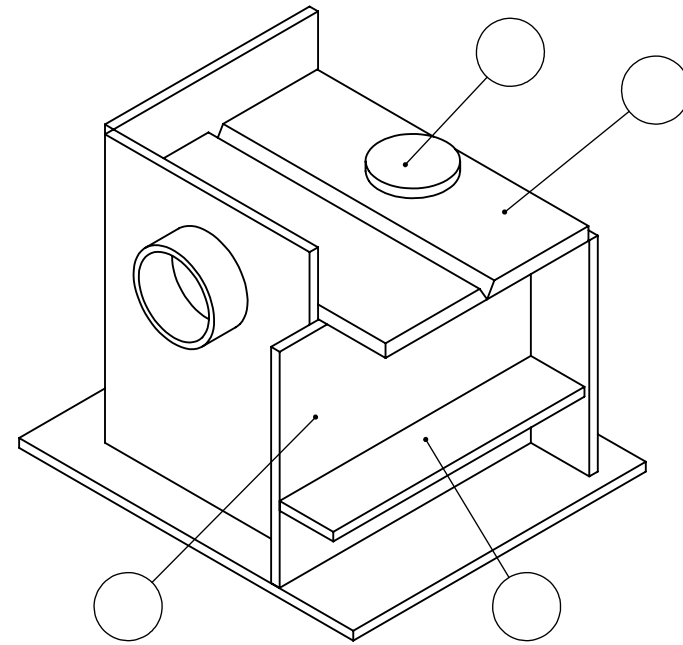

,620(75,& 9,(: '
98(,620<75,48('

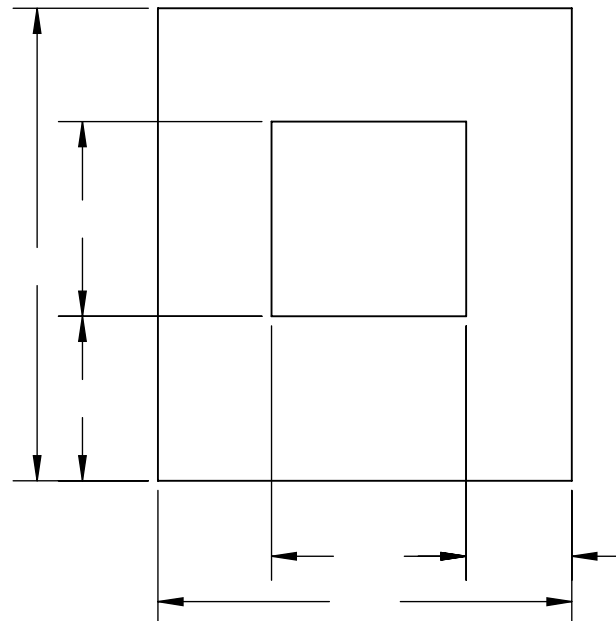

\$57,&/ (3\$57

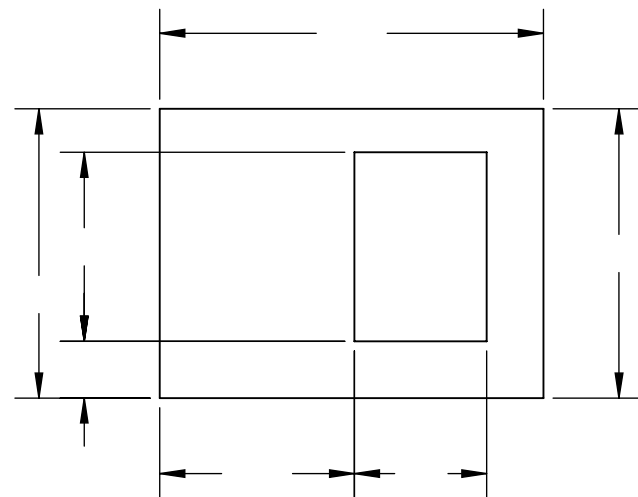

\$57,&/ (3\$57

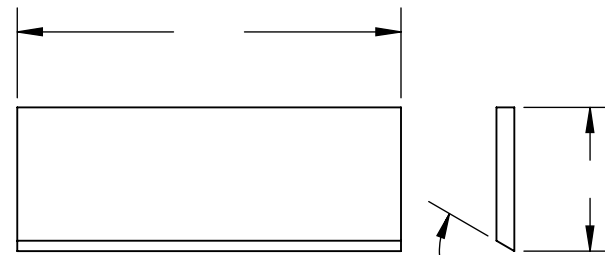

\$57,&/ (3\$57

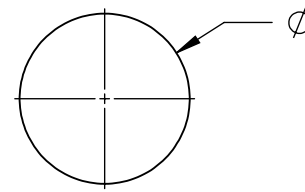

\$57,&/ (3\$57

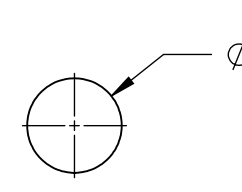

\$57,&/ (3\$57

,7(0 \$57,&/ ('(6&5,37,21	47< 47e
3	[[
3	[[
3	[[
3	[[
3	[[
3	[[
3	[[
3	[[
3	[[
3,3(78<\$8	6&+ 2'	, '[
3	∅	

727\$/ (67,0\$7(' :(*+7 %())25(:(/,1*
32,'6 727\$/ (67,0e \$9\$17 628'\$*(

35(3\$5(' *5229(',0(16,216
' ,0(16,216 '(6 5\$,185(6 35e3\$5e(6

\$// %(9(/ \$1' 9((35(3\$5\$7,216 \$6)2//2:6
35e3\$5(5 7287(6 /(6 628'85(6 (1 9 (7 (1 %,6(\$
&(& ,

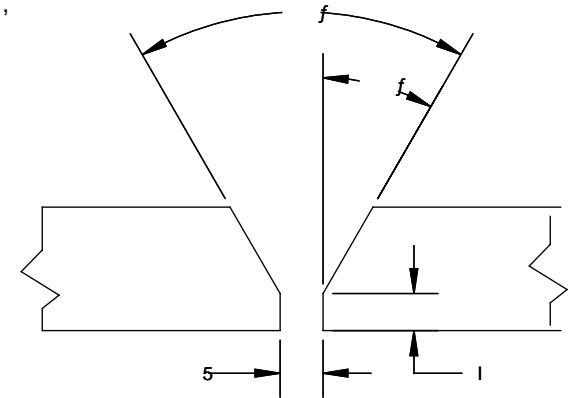

5 DQGDUH SUHSDUHG WR WKH SUHIHUHQFH RI W
7KH GLPHQVLRQ IRU WKH SODWHV VKRZQ LV W
DQ\ URRW JDS PXVW EH DFFRPRGDWHG LQ RYH
GLPHQVLRQV
5 HWWRQW SUPSDUpV VHQRQ OHV SUPIpUHQFHV
OD FRQFXUUHQWH /HV GLPHQVLRQV GHV SODT
FRPSWH G·XQ UHERUG DPLQL HW WRXW HVSDP
GRLW rWUH SULV HQ FRPSWH GDQV O·HQVHP
G·DVVHPEODJH

\$// ',0(16,216 ,1 0, //,0(7(56 7287(6 /(6 ',0(16,216 6217 (1 0

7,7/(PSCC	6(&21'\$5< '\$<	6+((7 12 '(3\$*(6,=(7\$,/(
		:25/' 9(66(/	2)	%
' : * 12	5(9	6&\$/(e&+(/ ('5\$:1 %< - +<' (
6&1& 6		'\$7(