

NOTES:

- TOP**
- VENEERED CORE WITH 60 MM SOLID MITRED EDGING
- UPPER CASE**
- MITRED PLYWOOD WITH 5 MM SOLID TOP EDGE
- KEYS ADDED TO CORNERS
- LOWER STAND**
- "X" FRAME LEGS WITH CROSS LAP JOINT
- CURVED STRETCHER WITH TUSKED THROUGH TENON

PROJECT:

MITRED CASE WITH STAND

LEVEL:

POST SECONDARY

DRAWING DESCRIPTION

ORTHO VIEWS, DETAILS 1 & 2

DATE:

DEC. 6, 2024

SCALE:

AS NOTED

DRAWN BY:

HB

SHEET:

1 OF 3

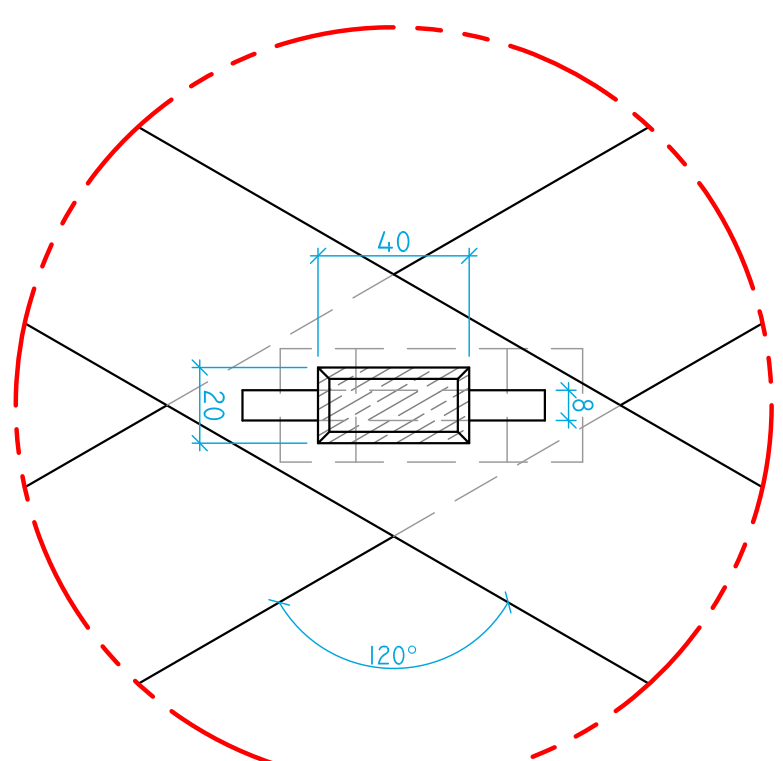
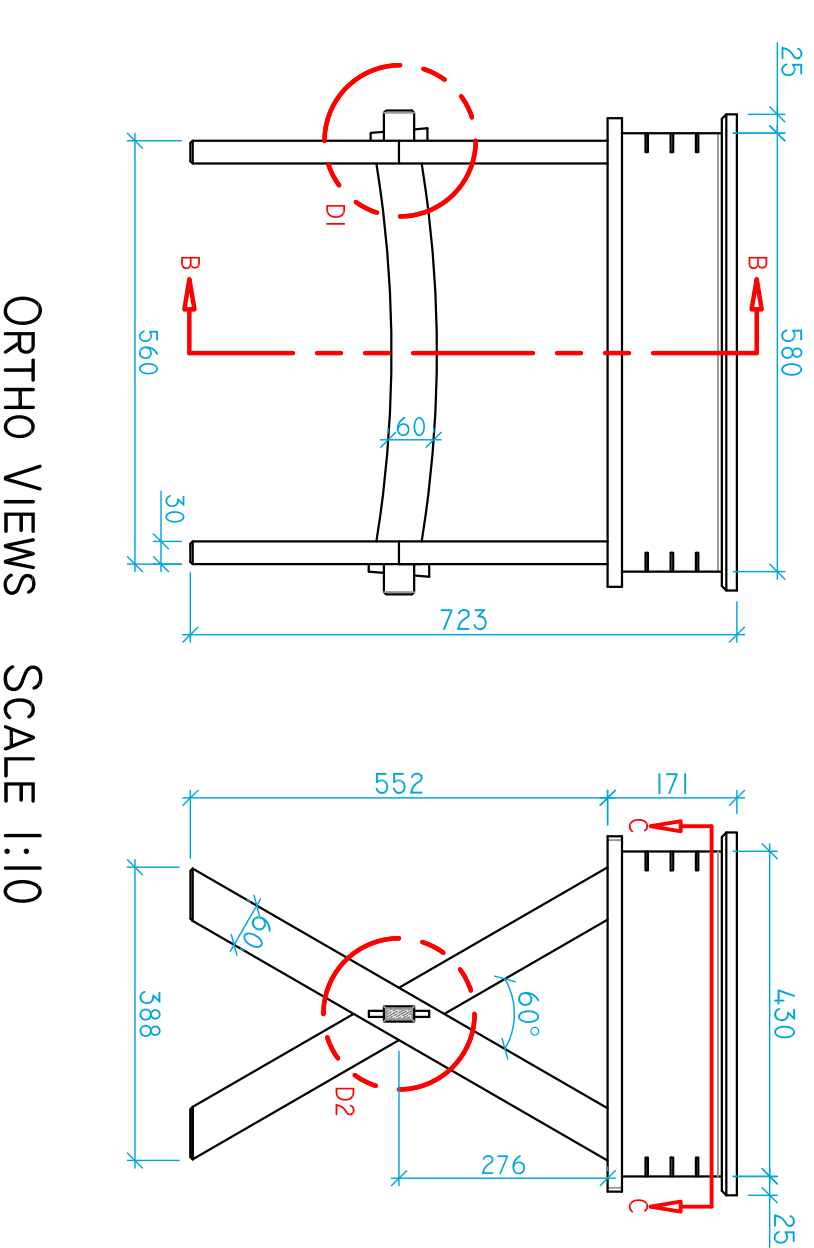
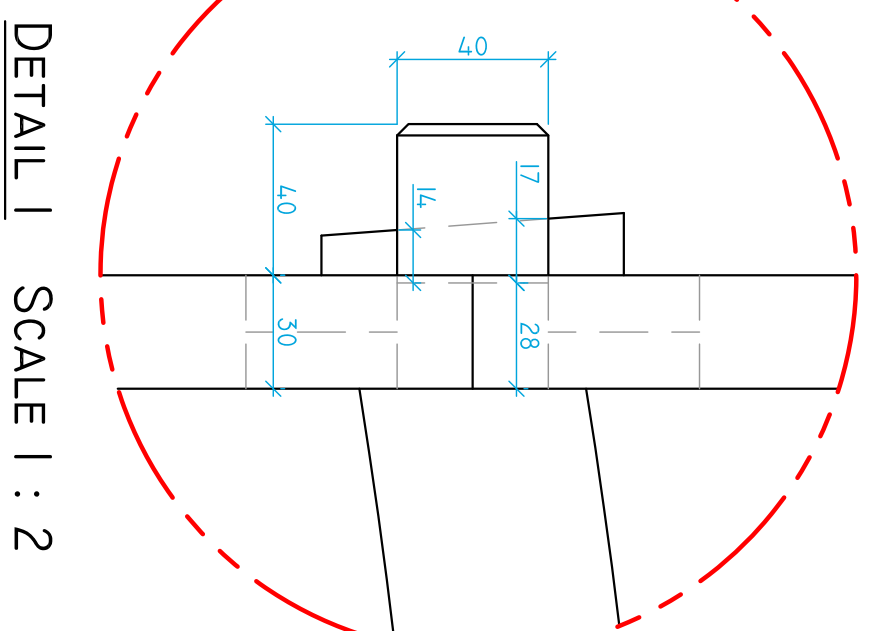
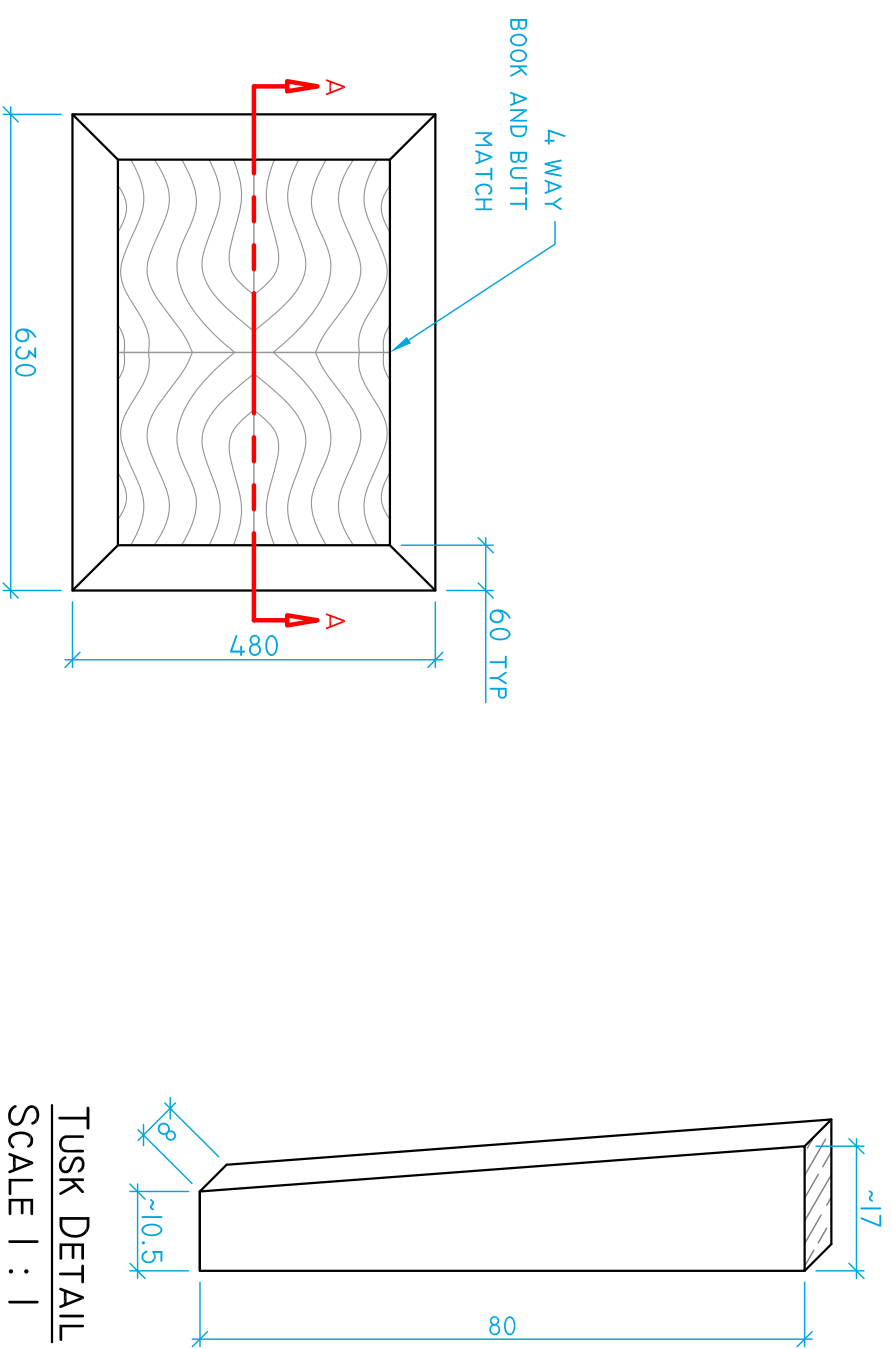

ORTHO VIEWS

SCALE 1:10

NOTE:
DRAWINGS FOR TRAINING PURPOSES ONLY
COMPETITION PROJECT MAY HAVE UP TO 30% CHANGE

NOTES:

- LID HINGED ON LONG SIDE
- NON-MORTISE LID HINGE
- 19 MM BOTTOM RABBETED IN
- DOVETAILED TRAY SLIDES ON
- 12 MM SOLID CLEATS
- PLYWOOD SUB TOP
- (BETWEEN CASE AND STAND)
- SUPPLIED TO SIZE
- CROSS LAP JOINERY ON LEG FRAMES

PROJECT:

MITRED CASE
WITH STAND

LEVEL:

POST
SECONDARY

DRAWING DESCRIPTION

SECTION A:A,
SECTION B:B

DATE:

Dc. 6, 2024

SCALE:

AS NOTED

DRAWN BY:

HB

SHEET:

2 OF 3

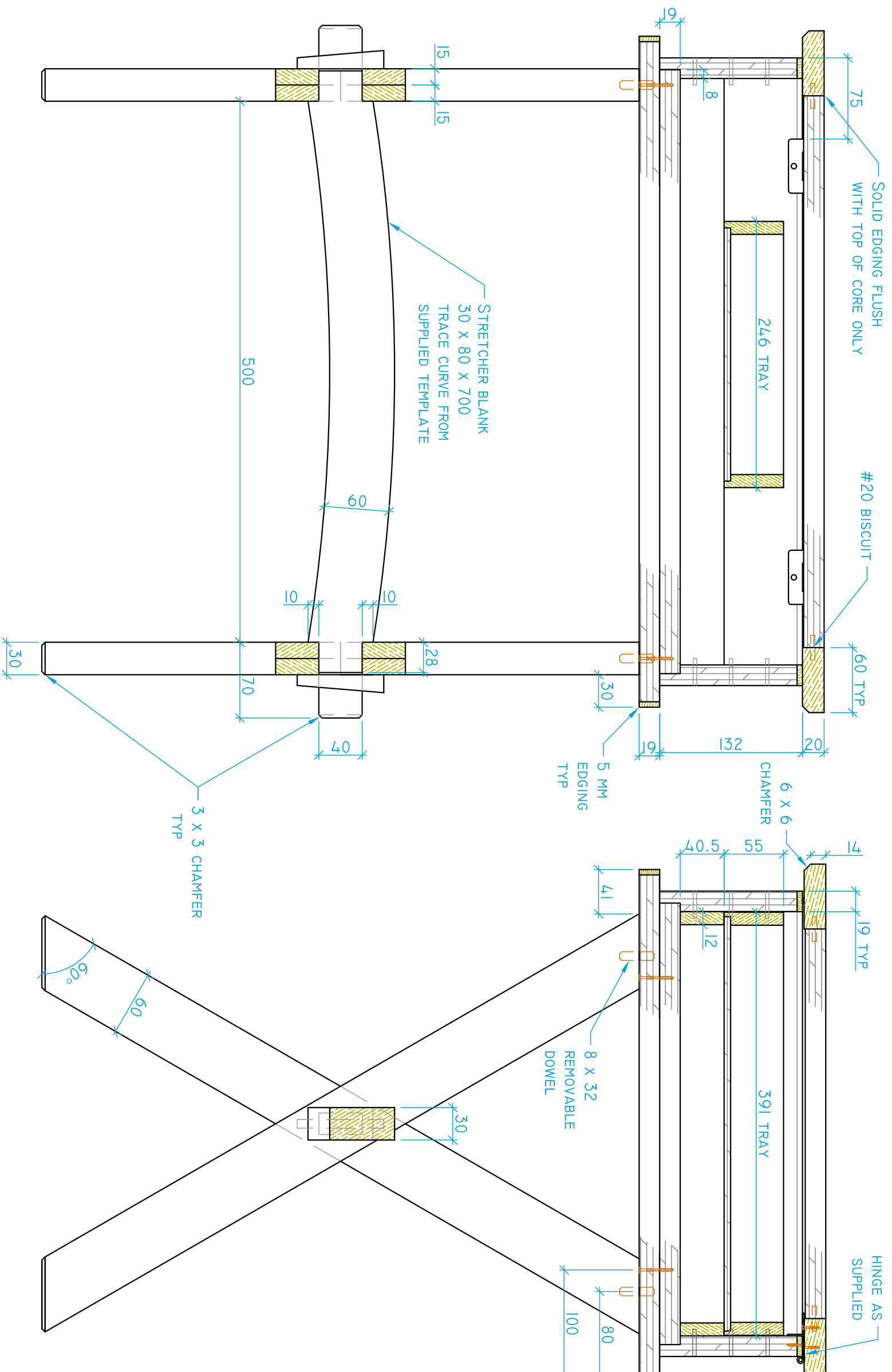

SECTION A : A SCALE 1:4

SECTION B : B SCALE 1:4

NOTE:
DRAWINGS FOR TRAINING PURPOSES ONLY
COMPETITION PROJECT MAY HAVE UP TO 30% CHANGE

NOTE:
DRAWINGS FOR TRAINING PURPOSES ONLY
COMPETITION PROJECT MAY HAVE UP TO 30% CHANGE

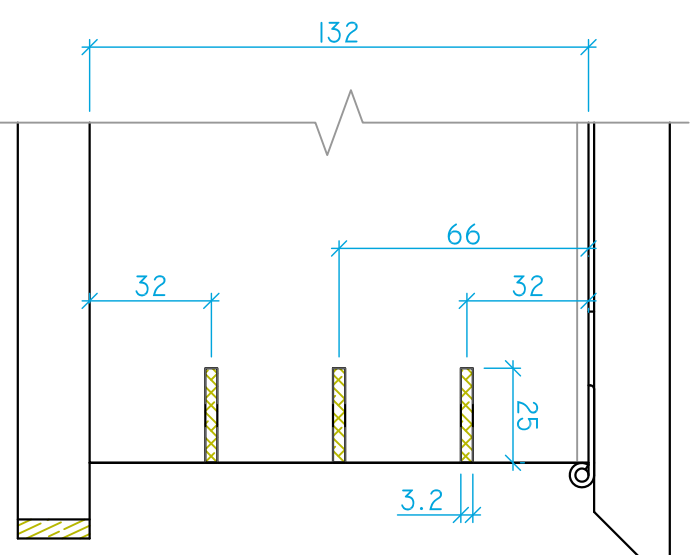
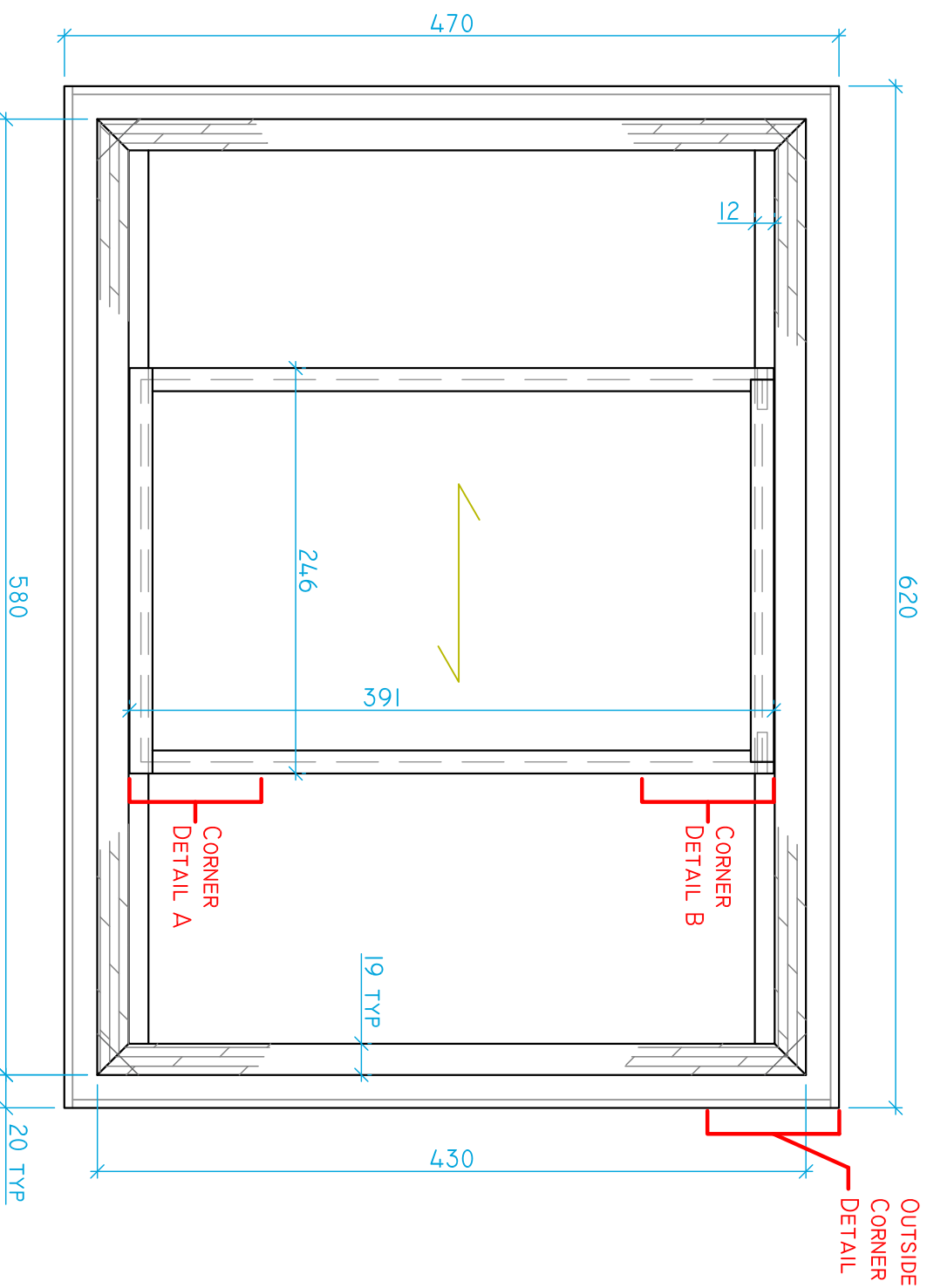

OUTSIDE CORNER DETAIL
SCALE 1 : 2

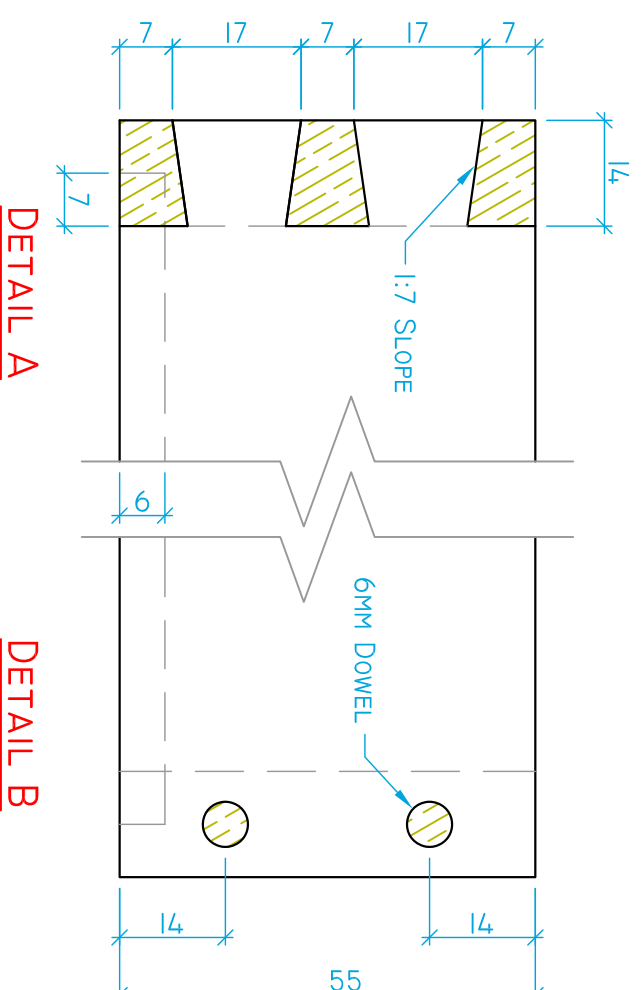

DETAIL A

DETAIL B

CORNER DETAIL
DOVETAIL TRAY
SCALE 1 : 1

SECTION C : C SCALE 1 : 4

NOTES:
- DOVETAIL JOINERY
HAND TOOLS ONLY
WILL BE MARKED BEFORE
AND AFTER ASSEMBLY
- MITRE KEY MATERIAL
SUPPLIED 3.2 THICK TO
MATCH SAW BLADE

PROJECT:
MITRED CASE
WITH STAND

LEVEL:
POST
SECONDARY

DRAWING DESCRIPTION
SECTION C:C
& TRAY DETAIL

DATE:
MAY 31, 2018

SCALE:
AS NOTED

DRAWN BY:
HB

SHEET:
3 OF 3