

Notes:

- Original concept from:  
Canadian Woodworking & Home  
Improvements

Material Required

- 2 - 2x4x8' SPF (38x89x2440)
- 4 - 2x2x8' SPF (38x38x2440)
- 6 - 1x6x8' SPF (19x140x2440)
- 4 - 1x4x8' SPF (19x89x2440)
- 1 - 2'x8'x3/4" Spruce plywood  
( 1/2 sheet)
- 2 - 3" Casters (Canadian Tire  
Grey Rubber #046-0717-8)
- 1 Handle (Canadian Tire  
#046-1661-2)
- 1 1/2", 2 1/2" & 3" Wood Screws
- 2 - 6" Wood Screws
- 4 - 1/4" x 4" Carriage bolts with  
nuts and washers



2025  
Regional Practice  
Lemonade Stand

Drawn: dr  
Date: Dec/1/2019  
Scale: n.t.s.

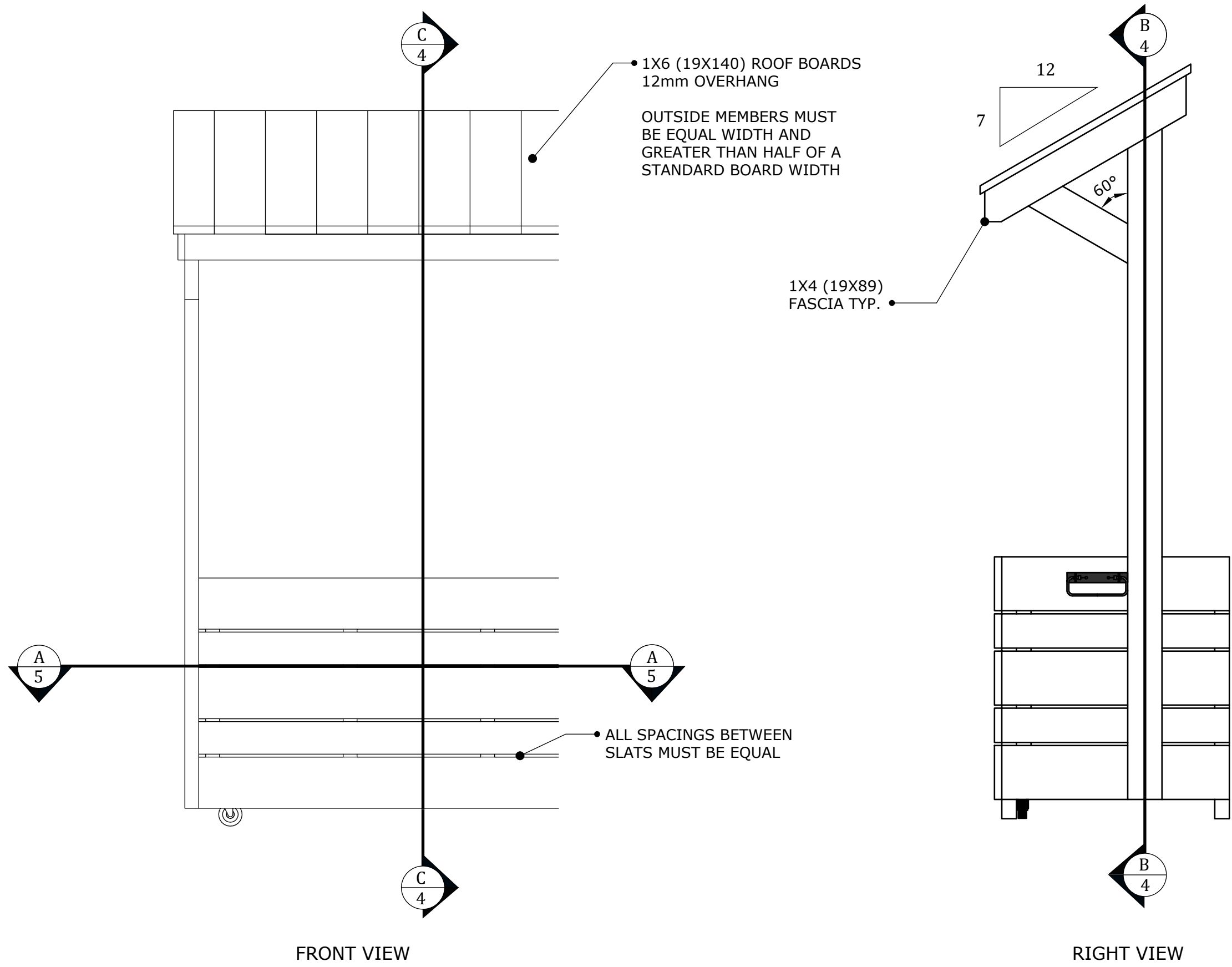

- Notes:
- All dimensions in millimetres
  - $\square$  indicates marking criteria
  - Slats 1x6 (19x140)
  - Keep wood screws aligned and equally spaced
  - All screws countersunk and flush with wood surface
  - Ease all edges
  - All roof boards overhang fascia 12mm on all sides



2025  
Regional Practice  
Lemonade Stand  
Elevations

Drawn: dr  
Date: Dec/1/2019  
Scale: n.t.s.

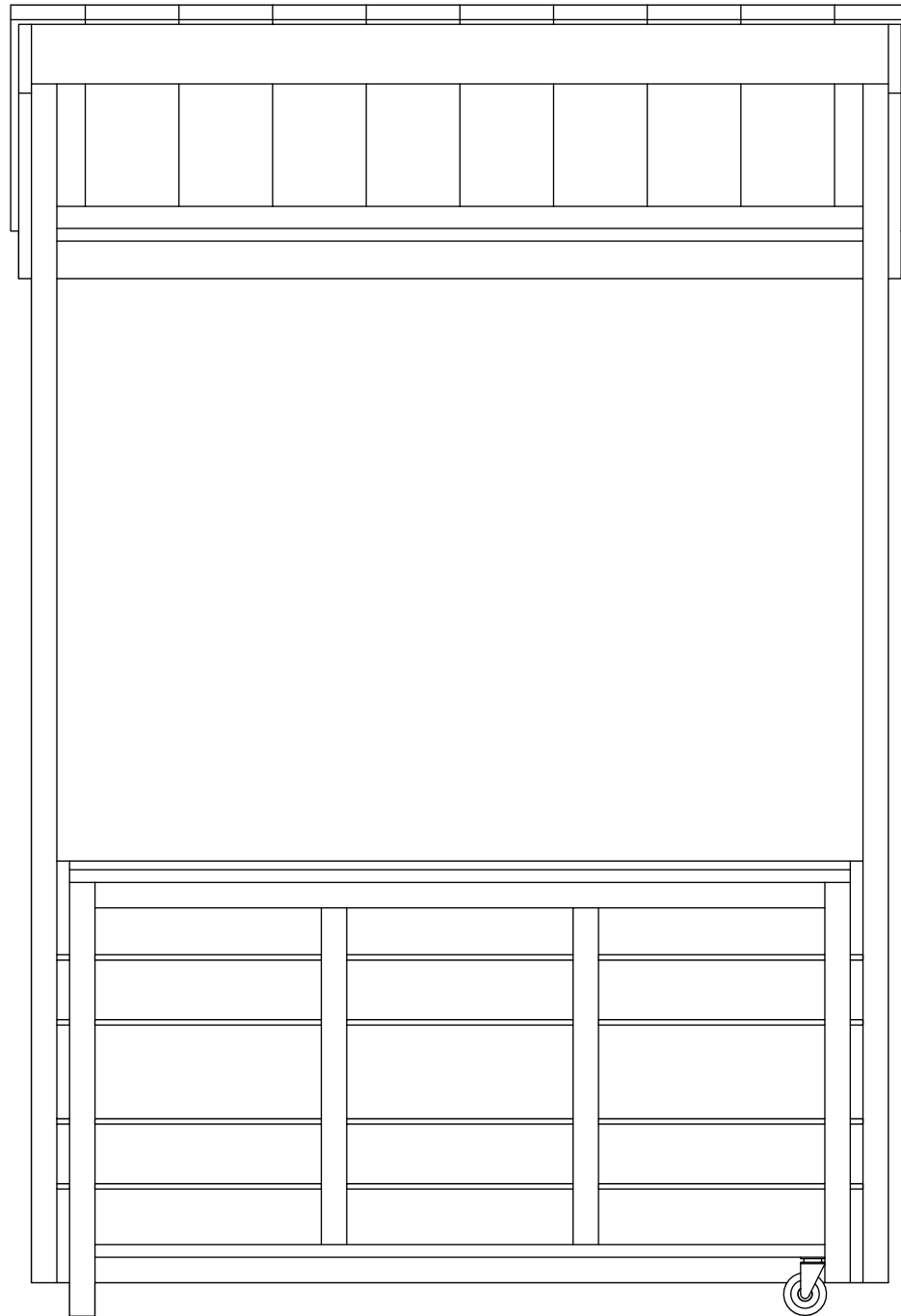

BACK VIEW

1/4" X 4" CARRIAGE BOLTS  
C/W NUTS AND WASHERS TYP.

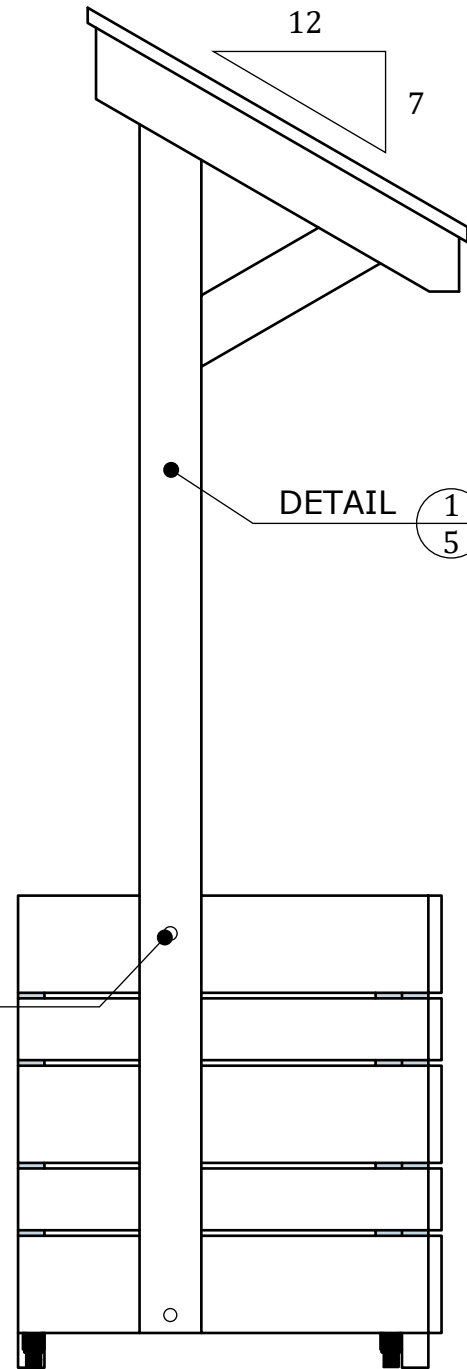

LEFT VIEW

Notes:

- All dimensions in millimetres
- Ⓢ indicates marking criteria
- Slats 1x6 (19x140)
- Keep wood screws aligned and equally spaced
- All screws countersunk and flush with wood surface
- Ease all edges
- All roof boards overhang fascia 12mm on all sides



2025  
Regional Practice  
Lemonade Stand  
Elevations

Drawn: dr

Date: Dec/1/2019

Scale: n.t.s.

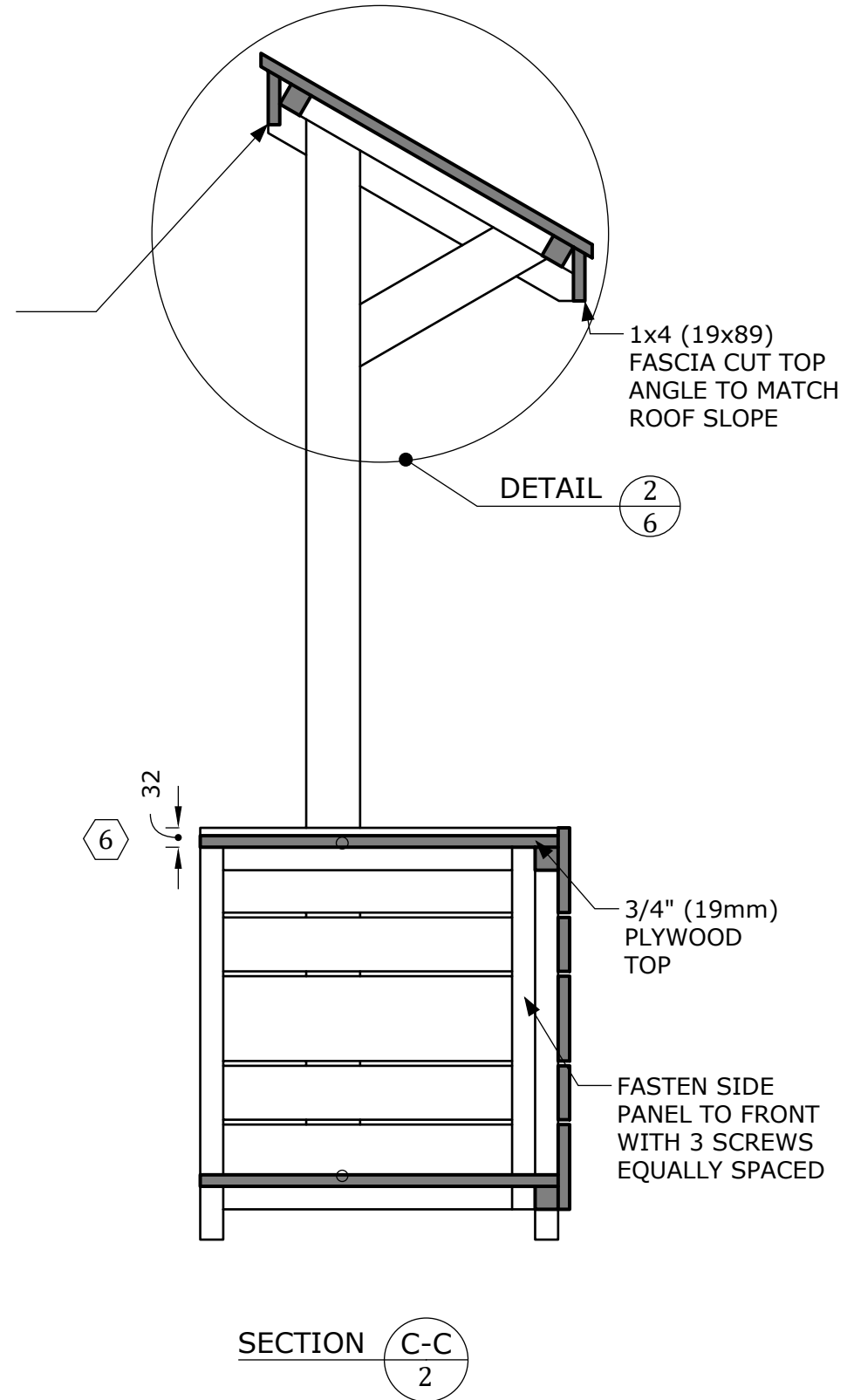
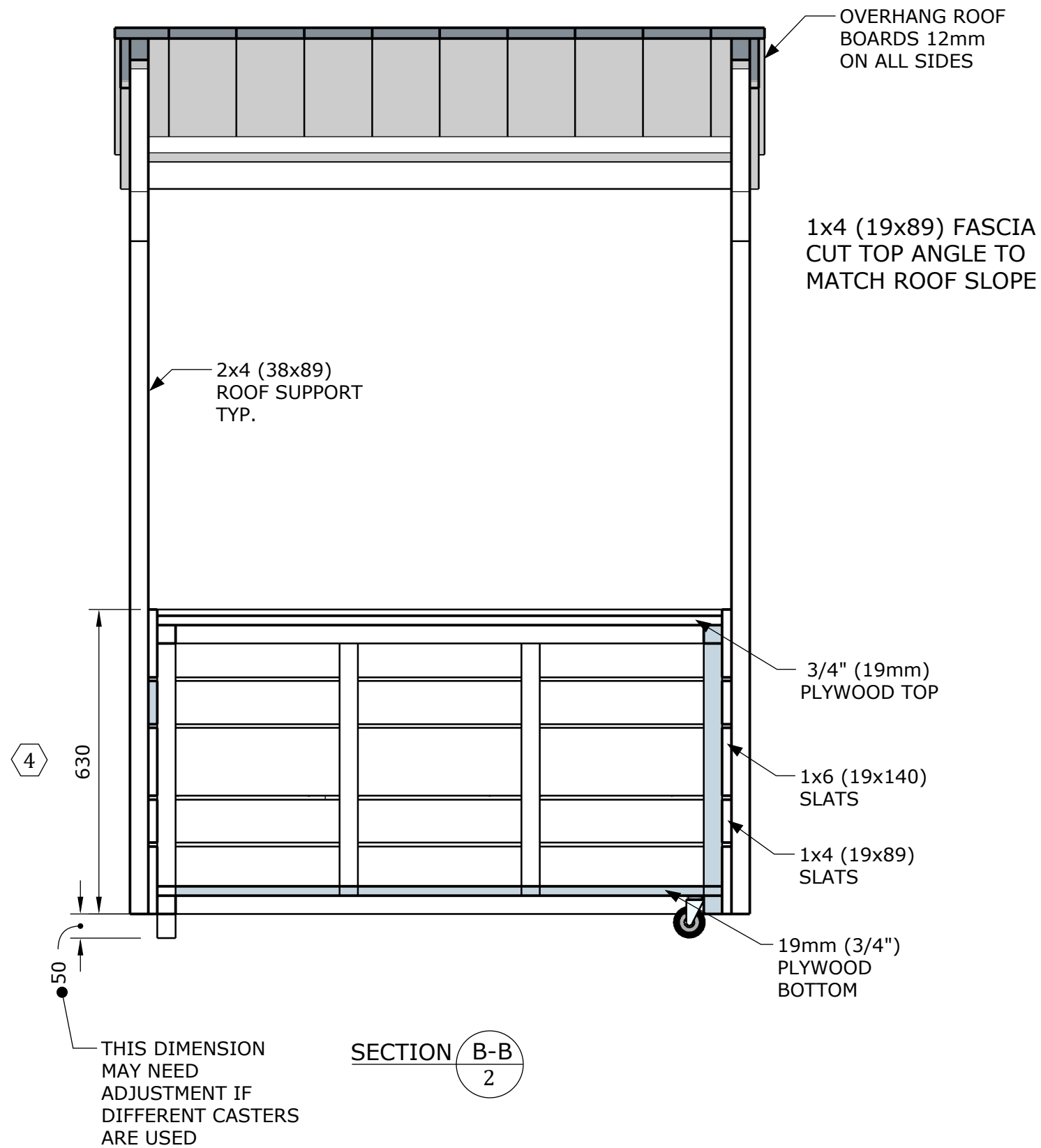

- Notes:
- All dimensions in millimetres
  - Ⓜ indicates marking criteria
  - Slats 1x6 (19x140)
  - Keep wood screws aligned and equally spaced
  - All screws countersunk and flush with wood surface
  - Ease all edges
  - All roof boards overhang fascia 12mm on all sides



2025  
Regional Practice  
Lemonade Stand  
Cross Sections

Drawn: dr

Date: Dec/1/2019

Scale: n.t.s.

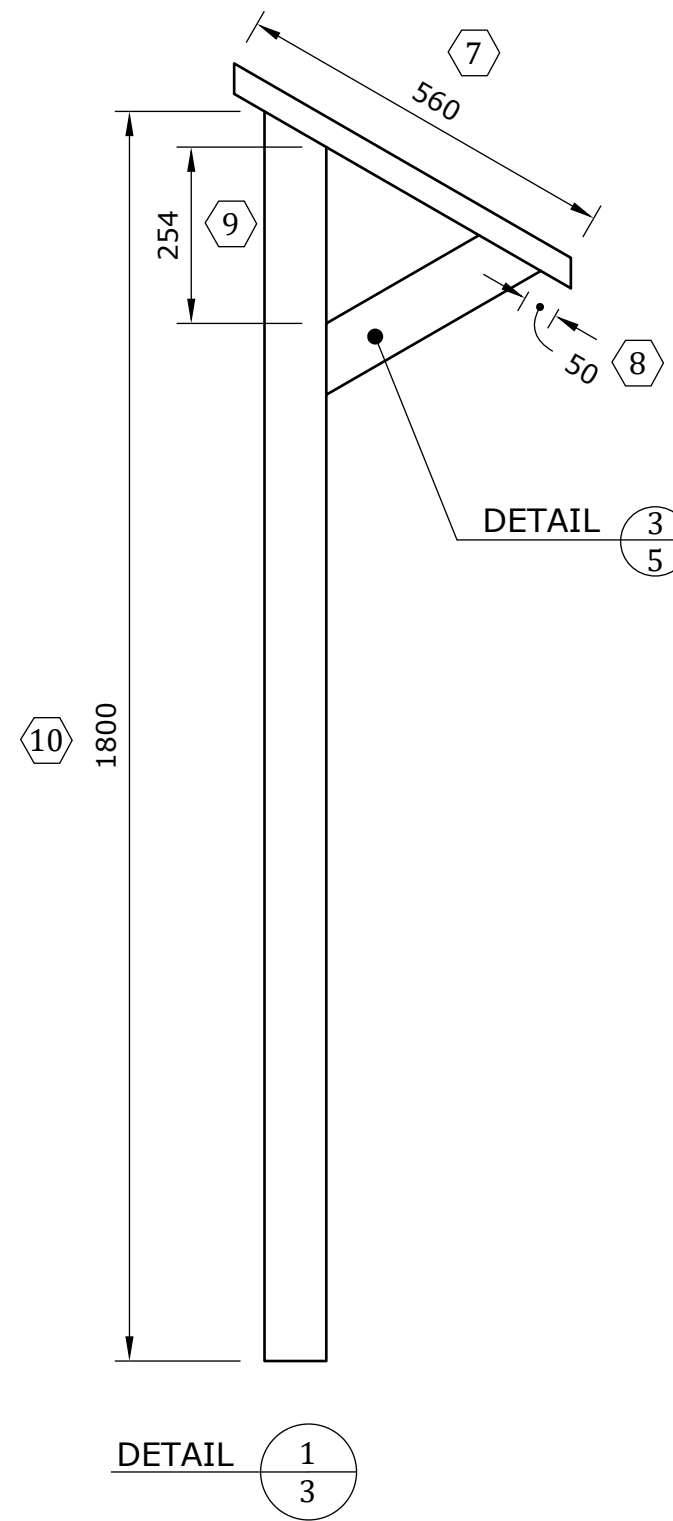
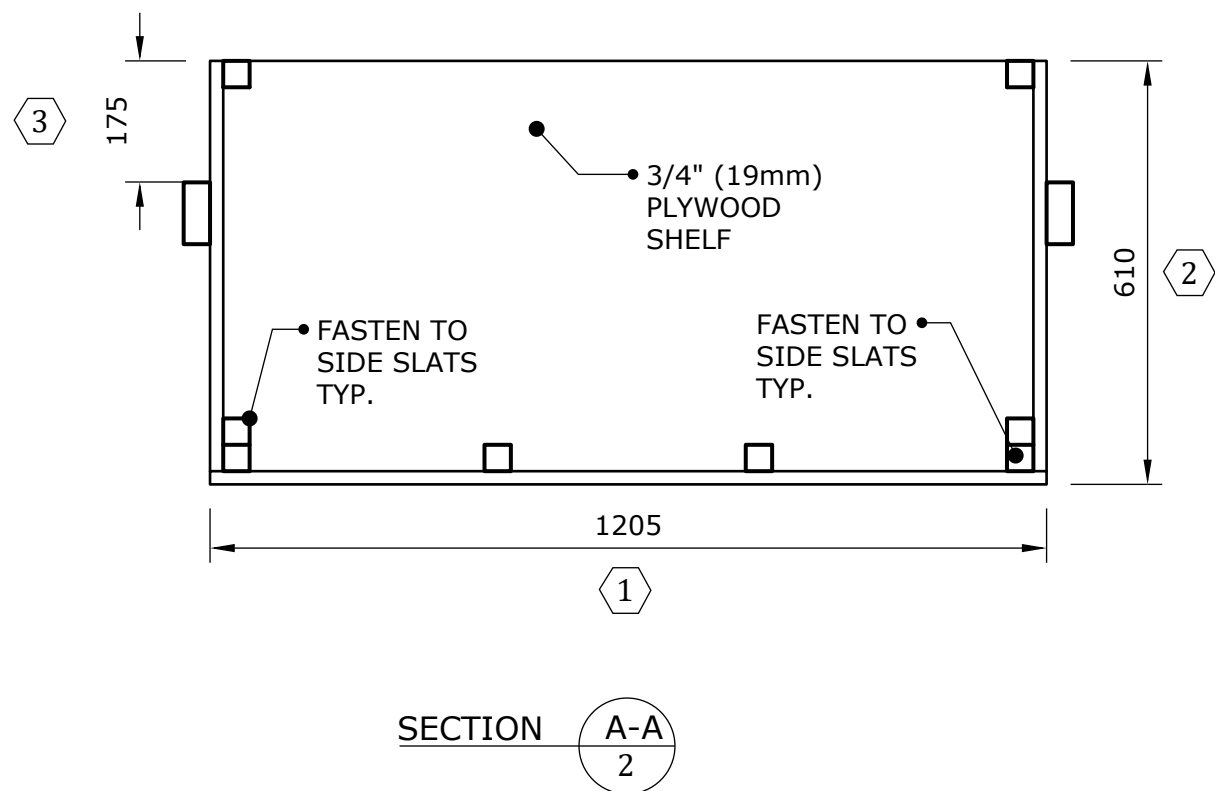
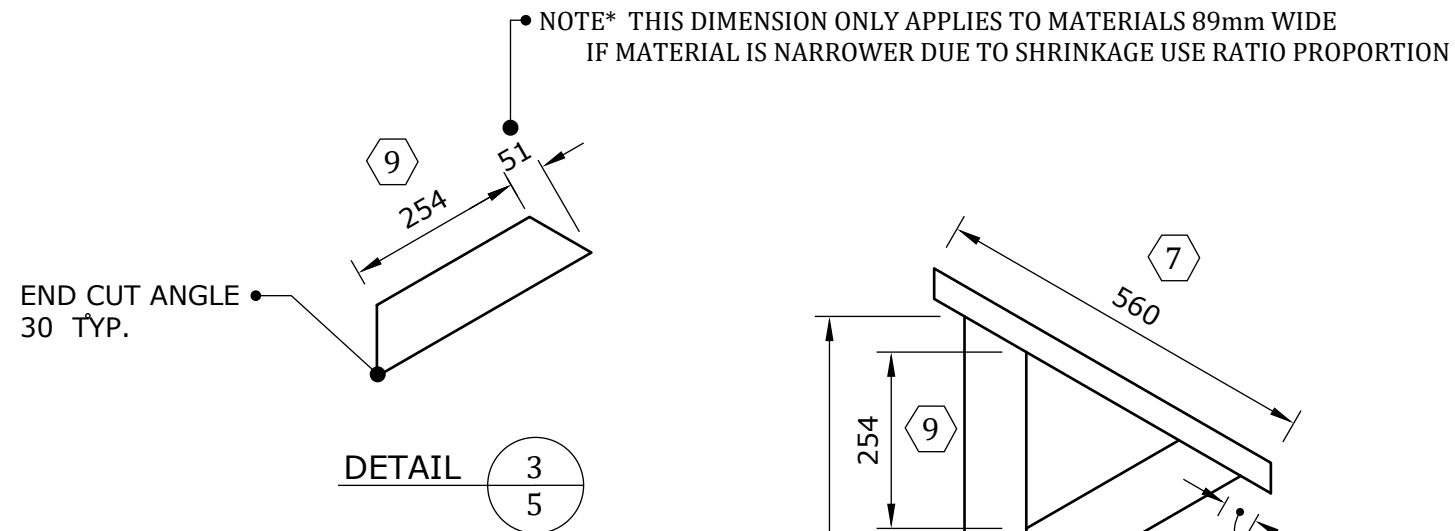
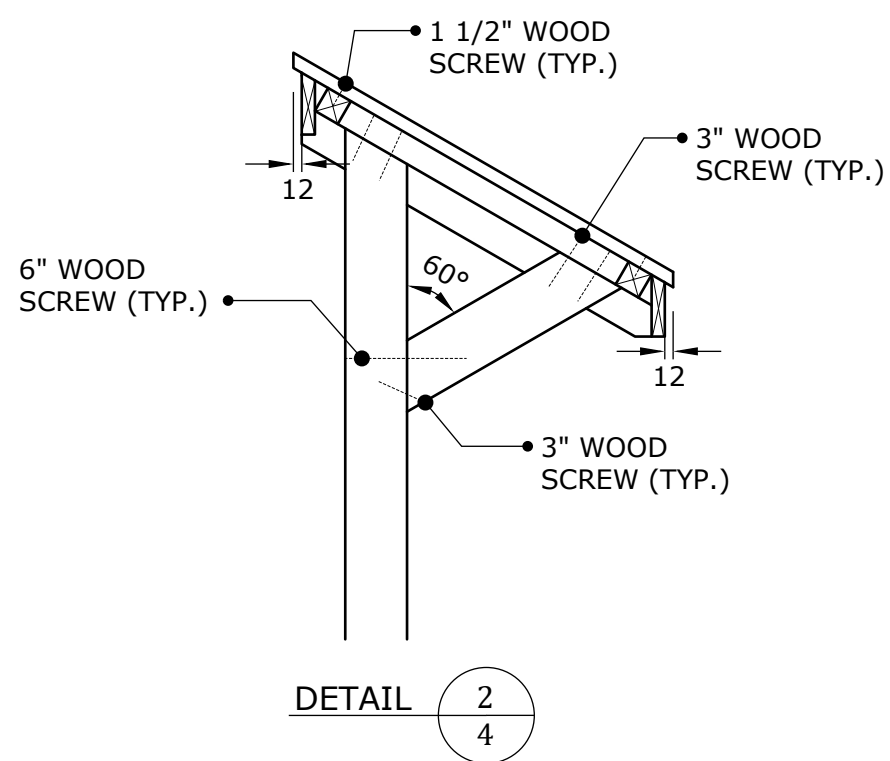

- Notes:
- All dimensions in millimetres
  - Ⓣ indicates marking criteria
  - Slats 1x6 (19x140)
  - Keep wood screws aligned and equally spaced
  - All screws countersunk and flush with wood surface
  - Ease all edges



2025  
Regional Practice  
Lemonade Stand  
Sections & Details

Drawn: dr

Date: Dec/1/2019

Scale: n.t.s.