



2025 South West Regional Skills Canada Competition

Contest Description

Lethbridge Polytechnic (3000 College Drive South, Lethbridge)

March 8, 2025

EVENT: Carpentry	LEVEL: Secondary										
DURATION OF CONTEST: 5.5 HOURS	LOCATION: LETHBRIDGE POLYTECHNIC, TR 1835										
COMPETITION SCHEDULE: <table border="1"> <tr> <td>CHECK IN (FOUNDERS' SQUARE)</td> <td>7:30 A.M.</td> </tr> <tr> <td>ORIENTATION</td> <td>7:45 A.M.</td> </tr> <tr> <td>COMPETITION BEGINS</td> <td>8:00 A.M.</td> </tr> <tr> <td>LUNCH</td> <td>11:45 – 12:15 P.M.</td> </tr> <tr> <td>COMPETITION ENDS</td> <td>2:00 P.M.</td> </tr> </table>	CHECK IN (FOUNDERS' SQUARE)	7:30 A.M.	ORIENTATION	7:45 A.M.	COMPETITION BEGINS	8:00 A.M.	LUNCH	11:45 – 12:15 P.M.	COMPETITION ENDS	2:00 P.M.	REGIONALIZED: YES If YES, To compete at the Provincial Skills Canada Competition students must qualify at their Regional Skills Canada Competition.
CHECK IN (FOUNDERS' SQUARE)	7:30 A.M.										
ORIENTATION	7:45 A.M.										
COMPETITION BEGINS	8:00 A.M.										
LUNCH	11:45 – 12:15 P.M.										
COMPETITION ENDS	2:00 P.M.										
AWARDS CEREMONY INFORMATION: The awards ceremony will be held at 4:00 p.m. in the Swing Space (AN1804). It is open to the public; parents are encouraged to attend.											

CONTEST INTRODUCTION

- To evaluate each contestant's competency to organize and execute a given work assignment accurately and safely in the carpenter trade.
- To recognize outstanding excellence and professionalism.

SKILLS AND KNOWLEDGE TO BE TESTED

- Demonstrate skills and competency in interpreting prints, shop drawings, and specifications.
- Demonstrate the safe use of hand and power tools.
- Demonstrate acceptable site management, housekeeping, and best practices.
- Proficient knowledge and demonstration of skill in; framing, cutting and drilling materials, fastening techniques, joinery, determining angles & elevations, trim & finishing.
- Quality, accuracy and thoroughness of workmanship.
- Ability to complete an assignment within a specified time frame.

PROJECT DESCRIPTION

Please see the attached practice plans released along with the contest description in addition to this isometric image. On the day of the Regional Competition, competitors will be provided the actual Competition Plans which may have been changed up to 30% from the practice set.



Lemonade Stand

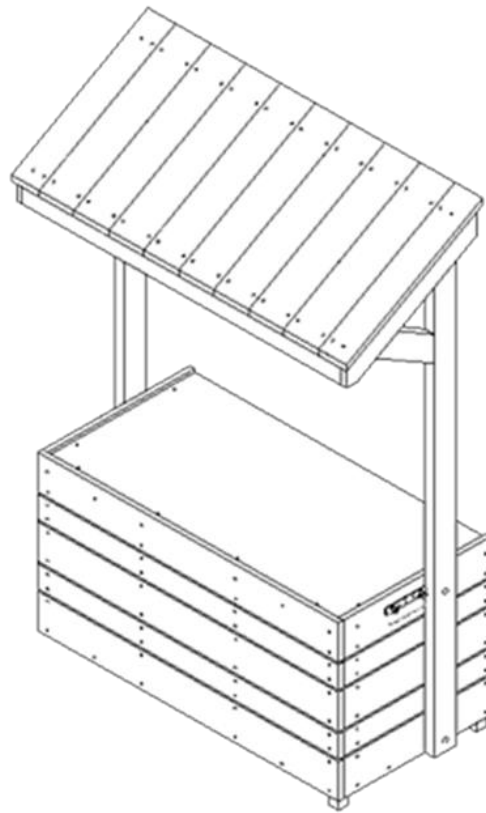

EQUIPMENT & MATERIALS

Equipment and Materials Supplied by Competitors:

Competitors are required to supply CSA approved footwear (green triangle standard), safety glasses and suitable work clothing, including gloves.

The following hand tools will be provided by the committee to any competitor who does not bring their own.

Measuring/Layout	Safety	Assembly Tools	Misc.
Pencils	Eyewear and Hard Hat (Loaners will be available)	Hammer / Mallet	Non-Programmable Calculator
Metric Tape Measure		Screwdriver (Rob #2)	Carpenters Apron
Framing Square			2 – Quick Clamps 12" min.
Speed Square	Cutting Tools	Disassembly Tools	Compass
Combination Square	Cross-cut Hand Saw	Examples:	
Sliding T-Bevel	Wood Chisels	Glazing Bar	
Stair Gauges	Utility Knife - not Olfa style	Nail Claw	
Chalk / Dry line	Block and /or Smooth Plane	Wonder Bar	

Equipment and Materials Supplied by the Committee:

Power Tools And Equipment		Safety	Materials
Cordless Drill	Saw Horses	Dust Masks	All materials and fasteners will be provided for the project
Cordless Impact Driver	Drill Bits	CSA approved hearing protection	
Cordless Jigsaw	Driver Bits		
Cordless Circular Saw	Clamps over 12"	Water Station	
	Sanding Block Sandpaper (100 grit)	First Aid Station	

**** No additional home-made jigs or gauges, power tools or power tools accessories will be allowed during the competition.***

**** Any tool or equipment not contained in the scope will be inspected and approved or removed by committee member.***

****NO personal electronic data devices (cell phones, smartphones, tablets, etc.) will be allowed in the competition area.***

SAFETY

The health, safety and welfare of all individuals involved with Skills Canada Alberta are of vital importance. Safety is a condition of participation with Skills Canada Alberta and shall not be sacrificed for the sake of expediency. At the discretion of the judges and technical committees, any competitor can be denied the right to participate should they not have the required proper safety equipment and/or act in an unsafe manner that can cause harm to themselves or others.

Safety Requirements: MANDATORY

- **CSA approved footwear – green triangle standard (Competitor)**
- **CSA approved hard hat (competitor can provide their own, loaners are available)**
- **CSA approved safety glasses (competitor) (Prescription glasses must conform to CSA regulations.)**
- **CSA approved hearing protection (Provided by Committee)**
- **Suitable work clothing (Competitor)**
- **Competitors are required to follow all industry safety standards during the competition.**

Clothing Requirement

It is important that competitors present a professional image and appearance. Appropriate work clothing must be worn to compete. All clothing must be neat and clean and free of rips and tears. Casual wear such as shorts will not be permitted. No loose-fitting clothes or jewelry. Competitor may bring work gloves to wear but are not mandatory.



JUDGING CRITERIA

• SAFETY/CLEAN-UP	15%
• DIMENSIONS	30%
• CONSTRUCTION	35%
• SALABILITY	10%
• MATERIAL USAGE	10%
<hr/>	
OVERALL TOTAL	100%

TIE BREAKING PROCESS

If two or more participants are tied in points at the end of the competition, the following tie breaking procedure will be used:

- Step 1.** Participant with the highest Safety score.
- Step 2.** Participant who has completed the project in the least amount of time.
- Step 3.** Re-evaluate the projects with different judges.

RELATED CAREER AND TECHNOLOGY STUDIES COURSES

Descriptions of all modules are located at the following website:

https://education.alberta.ca/media/160534/con_course_summaries_old.pdf

CRA 3407	HAND TOOLS THEORY
CRA 3417	PORTABLE POWER TOOLS
CRA 3452	SKETCHING & DRAWINGS
CRA 3457	DRAWING PRINCIPLES
CON 1010	CONSTRUCTION TOOLS AND MATERIALS
CON 1070	BUILDING CONSTRUCTION
CON 1120	PRODUCT MANAGEMENT
CON 1130	SOLID STOCK CONSTRUCTION
CON 2035	FRAMING SYSTEMS - FLOOR
CON 2045	FRAMING SYSTEMS – WALL
CON 2050	ROOF STRUCTURES 1

ADDITIONAL INFORMATION

Lunch will be provided for all competitors, teachers, judges and volunteers. Your lunch ticket will be at the back of your name tag. Unfortunately, all allergies may not be able to be accommodated for. Please contact the local Regional Coordinator for more information.

PARKING INFORMATION & VENUE MAPS

Please park in Lot V – there is no charge. Overflow will also be allowed in Lot P. A printable parking map of Lethbridge Polytechnic can be found at <https://lethpolytech.ca/document-centre/facilities-management/parking-map>

Regulations & Policies: A copy of the Skills Canada Alberta Regional Regulations & Policies can be found at the following link: <https://skillsalberta.com/policies-and-procedures>





EVENT SCHEDULE

7:30	Competitor check-in at Founders' Square
7:45	Introduction, Orientation & Safety
8:00	Competition Begins
11:45	Lunch Break – 30 minutes
12:15	Competition resumes
2:00	Competition ends – Judging Begins
4:00	Awards Ceremony (Swing Space - AN1804) – open to the public

LOCAL REGIONAL COMPETITION COMMITTEE MEMBERS

Tyrel Churko	Lethbridge Polytechnic
Brody Forster	Lethbridge Polytechnic
Zac Harris	Matthew Halton High School
Holly Lehbauer	Career Transitions
Corby Pankhurst	Community Member
Shawn Scotney	Lethbridge Polytechnic
Judy Stolk-Ingram	Career Transitions
Leon Wensmann	Community Member

