

Note: Must be tacked up before welding and placed flat on table, No flipping project when welding
 All groove welds full penetration .

DRAWN Scott Friesen	28/01/2014			
		SIZE A	REV 1.3	SHEET 1 OF 1

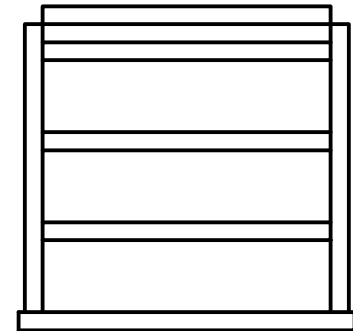
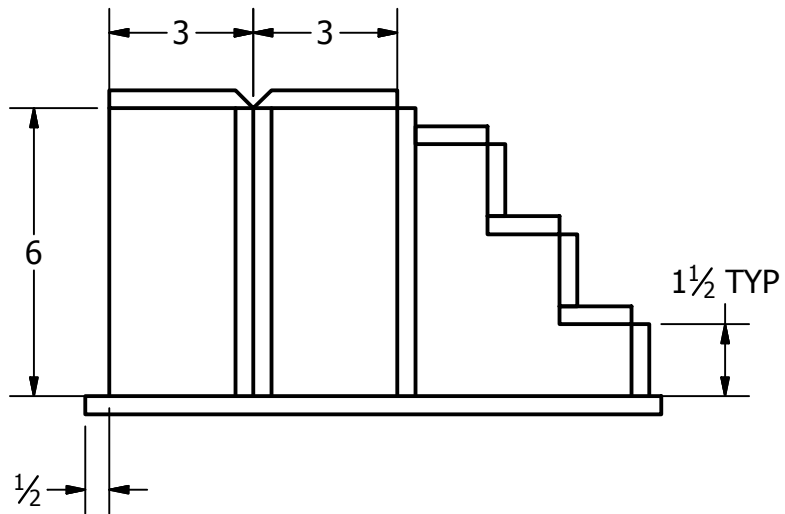
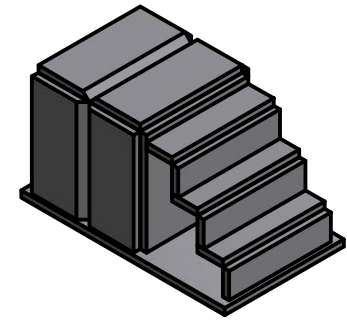
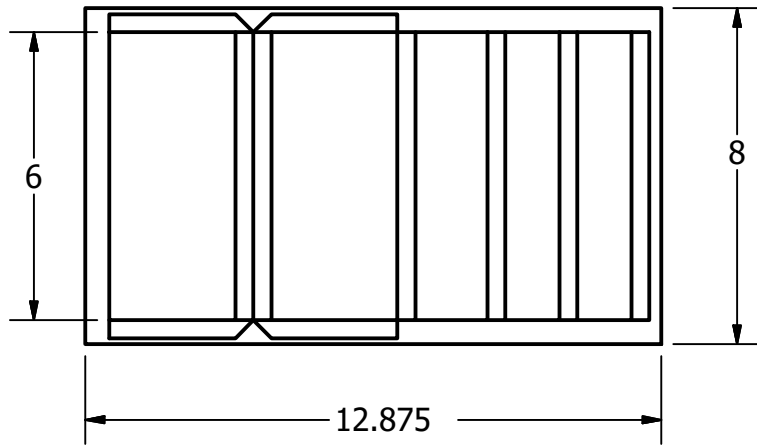
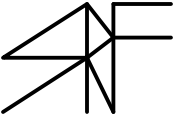

DRAWN Scott Friesen		29/01/2014			
					
		SIZE A	REV 1.3	SHEET 1 OF 1	